

SINGER
993BX3,B3,BX10,B10,BX43,B43,BX50
B50

Parts List

SINGER

Index

	Page
993BX3 machine parts list	52 to 81
993B3 machine parts list	82 to 85
993BX10 machine parts list	82 to 85
993B10 machine parts list	82 to 85
993BX43 machine parts list	86 to 87
993B43 machine parts list	86 to 87
993BX50 machine parts list	86 to 87
993B50 machine parts list	86 to 87
Accessories	74 to 81
Special tools	74
Numerical list of parts	89 to 91

Parts List for 993BX3 Machine

Ref. No.	Part No. For Ordering	Description	Amt. Req.
1	108225	Differential Feed Regulating Lever Thumb Nut Retainer	
2	113194	Differential Feed Regulating Lever Thumb Nut	
3	59456(891)	Differential Feed Regulating Lever Thumb Nut Washer	
4	107857	Differential Feed Regulating Lever	
5	107965	Differential Feed Regulating Lever Shaft Oil Ring	
6	107870	Differential Feed Regulating Lever Shaft Collar with 141292(869)	
7	141292(869)	Differential Feed Regulating Lever Shaft Collar Set Screw	
8	114134(869)	Differential Feed Regulating Lever Return Spring Arm Clamping Screw	
9	108132	Differential Feed Regulating Lever Return Spring Arm with 114134(869) and 141292(869)	
10	108134	Differential Feed Regulating Lever Return Spring Arm 108132 with 108135	
11	108135	Differential Feed Regulating Lever Return Spring Arm Pin	
12	141292(869)	Differential Feed Regulating Lever Return Spring Arm Pin Set Screw	
13	108012	Differential Feed Driving Arm with 114134(869) and 141292(869)	
14	108075	Differential Feed Driving Arm 108012 with 9525 and 107868	
15	114134(869)	Differential Feed Driving Arm Clamping Screw	
16	141292(869)	Differential Feed Driving Arm Stud Set Screw	
17	9525	Differential Feed Driving Arm Stud Washer	
18	108336	Differential Feed Driving Arm Connecting Link	
19	107868	Differential Feed Driving Arm Stud	
20	1209(892)	Differential Feed Regulating Lever Stop Screw	2
21	704(892)	Differential Feed Regulating Plate Securing Screw	2
22	131695(892)	Differential Feed Regulating Lever Stop Screw Washer	2
23	107859	Differential Feed Regulating Plate	
24	107854	Differential Feed Regulating Lever Stop	2
25	108145	Differential Feed Regulating Lever Return Spring	
26	108133	Differential Feed Regulating Lever Return Spring Anchor Pin	
27	350687(869)	Machine Frame End Cover Securing Screw	6
28	165373	Machine Frame End Cover Dowel Pin	2
29	108373	Machine Frame End Cover Hole Plug	

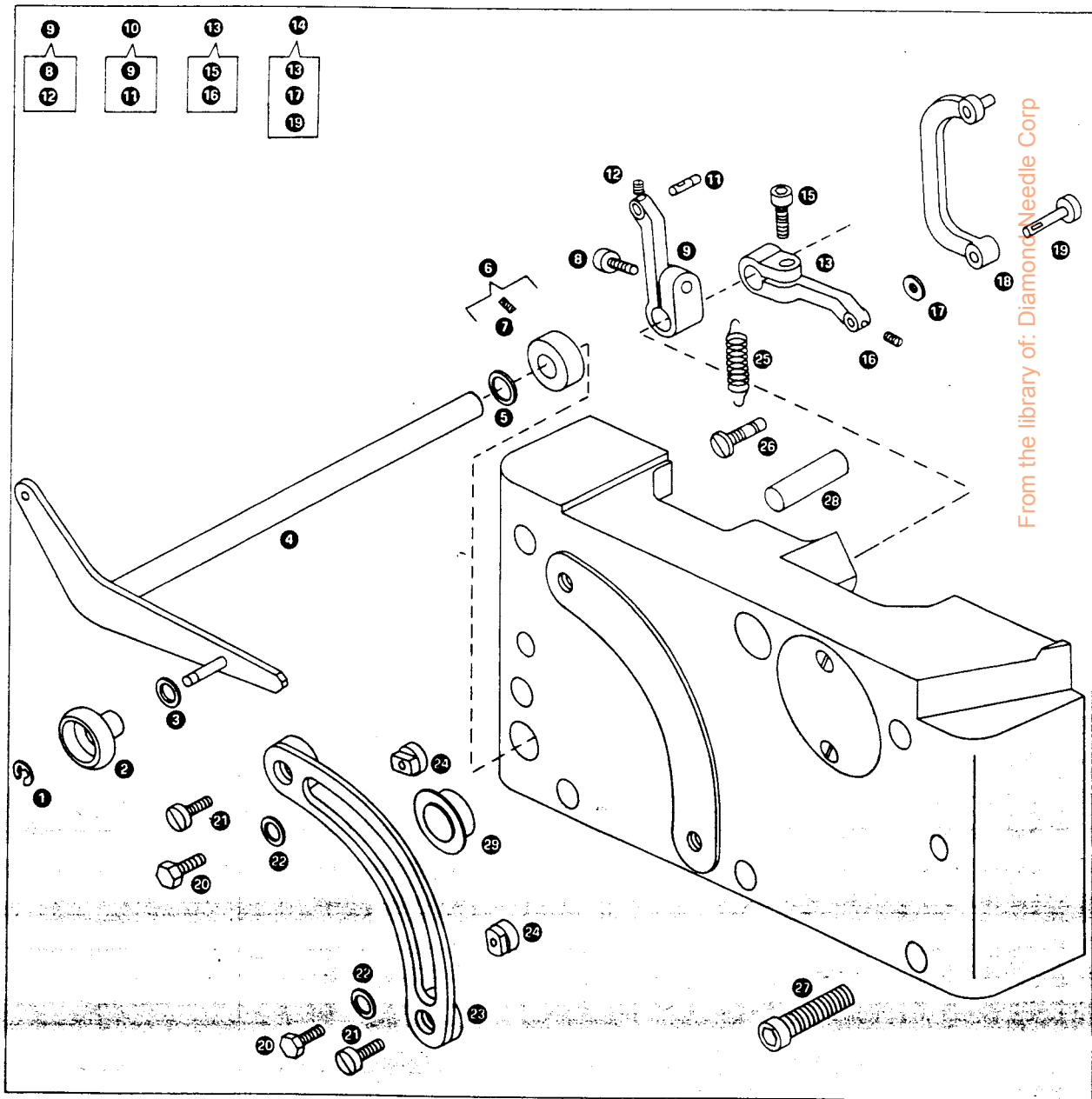
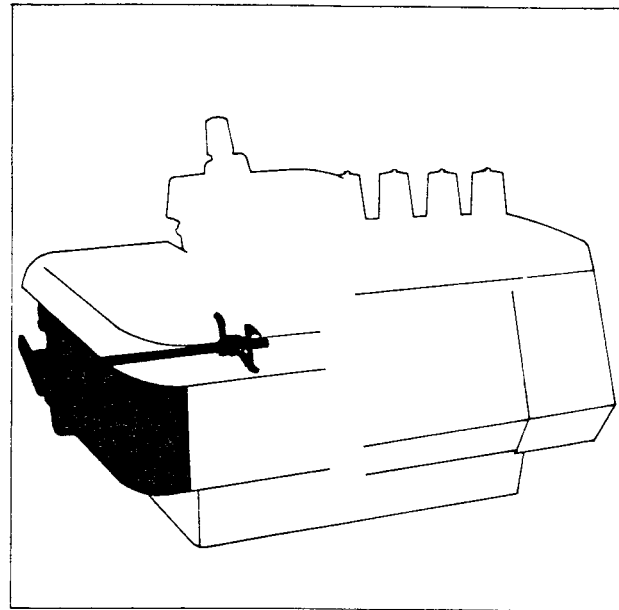

From the library of: Diamond Needle Corp

Parts List for 993BX3 Machine

Ref. No.	Part No. For Ordering	Description	Amt. Req.
1	106477	Looper (left hand) Driving Shaft Bushing (back)	
2	106477	Looper (right hand) Driving Shaft Bushing (back)	
3		Machine Frame Rotary Shaft with Looper (left and right hand) and Needle Driving Shafts Crank Connections. Note: The major components of this mechanism are selectively mated. Therefore only a complete replacement mechanism will be supplied from Clydebank Factory should any of the major components require replacement. However the Needle Driving Shaft Crank Clamping Screw No. 114091(869), the Looper Shafts Crank Clamping Screws No. 114092(803), the Crank Connections Cap Screws (lower) No. 171 (830), Crank Connections Cap Screws (upper) No. 140159(830) and the Rotary Shaft Oil Metering Pin No. 107037 can be supplied and fitted as replacements without disturbing the selective mating of the major components.	
4	140930(869)	Looper (left hand) Driving Shaft Crank Position Screw	
5	140930(869)	Looper (right hand) Driving Shaft Crank Position Screw	
6	106473	Looper (left hand)	
7	164053	Looper (left hand) Driving Shaft Crank Thrust Bearing	
8	106478	Looper (left hand) Driving Shaft Bushing (front)	
9	108917	Looper (left hand) Driving Shaft	
10	108371	Looper (left hand) Thread Tube (lower)	
11	853(830)	Looper (left hand) Thread Tube (lower) Set Screw	
12	51369(803)	Looper (left hand) Thread Tube (lower) Holder Screw	
13	164053	Looper (right hand) Driving Shaft Crank Thrust Bearing	
14	106492	Looper (right hand) Driving Shaft Bushing (front)	
15	108919	Looper (right hand) Driving Shaft with 106494	
16	225(819)	Looper (right hand) Carrier Connecting Link Adjusting Sleeve Wick Clip Screw	
17	20822	Looper (right hand) Carrier Connecting Link Adjusting Sleeve Wick Clip	
18	87027	Looper (right hand)	
19	132584	Looper (right hand) Carrier Connecting Link Hinge Pin Oil Wick	
20	106494	Looper (right hand) Driving Shaft Oil Wick	
21	101970	Looper (right hand) Position Coilar	
22	164068	Looper (right hand) Locking Screw Stud	
23	1700(809)	Looper (right hand) Locking Screw Stud Nut	
24	109927(869)	Looper (right hand) Carrier Connecting Link Hinge Pin Set Screw	
25	108925	Looper (right hand) Four-Bar Linkage Mechanism Note: The major components of this mechanism are selectively mated. Therefore only a complete replacement mechanism will be supplied from Clydebank Factory should any of the major components require replacement.	
26	106497	Looper (right hand) Four-Bar Linkage Mechanism Stabiliser with 106498 and two 350680(869)	
27	1083(830)	Looper (right hand) Driving Lever Clamping Screw	
28	109795(803)	Looper (right hand) Carrier Connecting Link Adjusting Screw (front)	
29	106496	Looper (right hand) Four-Bar Linkage Mechanism Stabiliser	
30	106498	Looper (right hand) Four-Bar Linkage Mechanism Stabiliser Support Bracket	
31	350680(869)	Looper (right hand) Four-Bar Linkage Mechanism Stabiliser Screw	2
32	114136	Looper (right hand) Four-Bar Linkage Mechanism Stabiliser Securing Screw	2
33	164046	Looper (left hand) Carrier with 141292(869), 114224(869) and 164202	
34	164202	Looper (left hand) Stop Pin	
35	114224(869)	Looper (left hand) Set Screw	2
36	1324(803)	Looper (left hand) Carrier Screw	
37	59456	Looper (left hand) Carrier Washer	
38	141292(869)	Looper (left hand) Carrier Set Screw	2
39	164660	Looper (left hand) Carrier Holder with 1083(830), 140393(830) and 140596(836)	
40	1083(830)	Looper (left hand) Carrier Holder Clamping Screw	
41	140596(830)	Looper (left hand) Carrier Holder Set Screw (left)	
42	140393(830)	Looper (left hand) Carrier Holder Set Screw (right)	
43	164661	Looper (left hand) Carrier Holder 164660 with 1324(803), 59456 and 164046	
44	108612	Looper (left hand) Thread Tube (lower) Holder with 853(830)	
45	1209(830)	Looper (right hand) Driving Lever Clamping Screw	2
46	114133	Needle Driving Shaft Crank Position Screw	

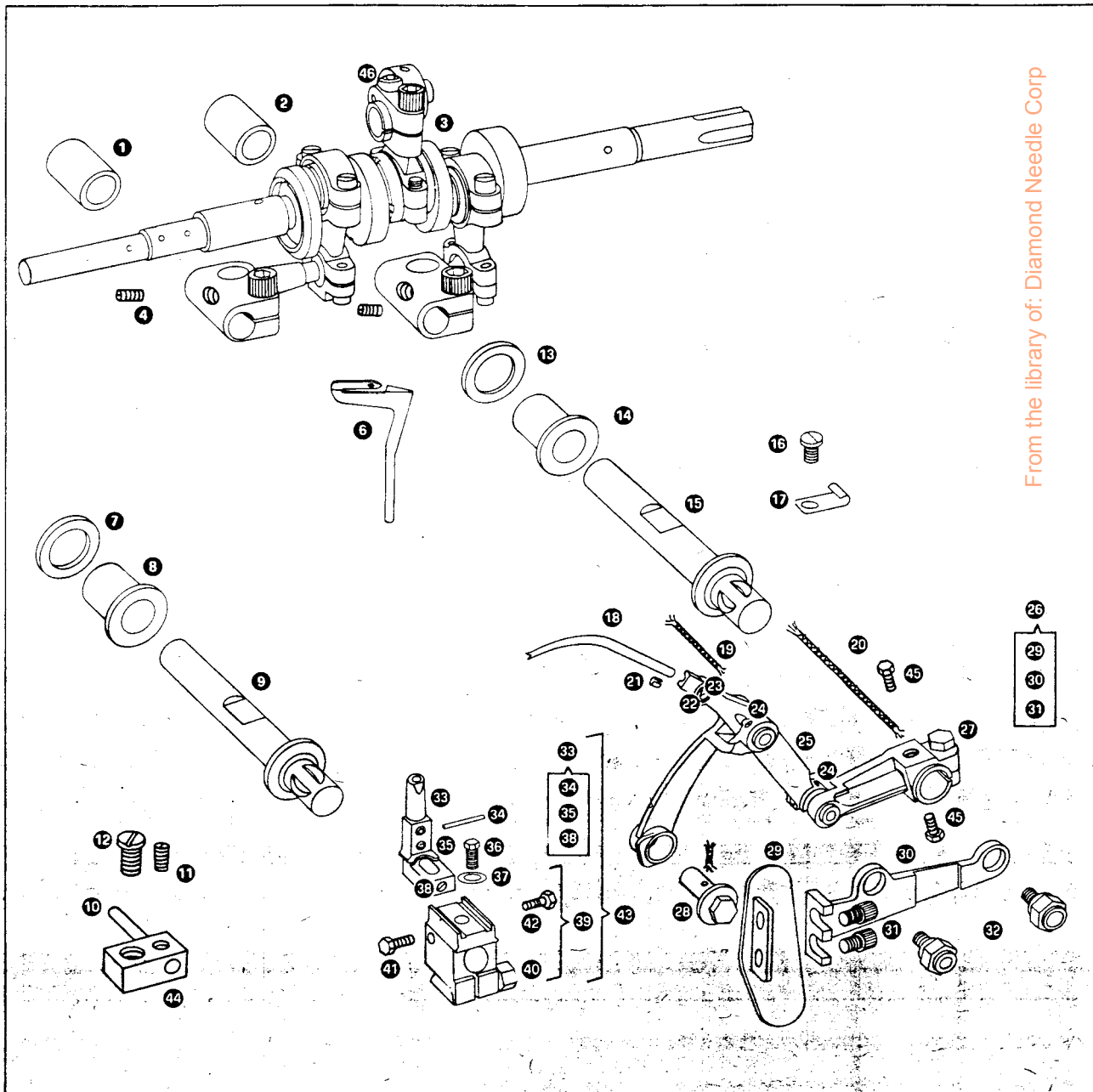
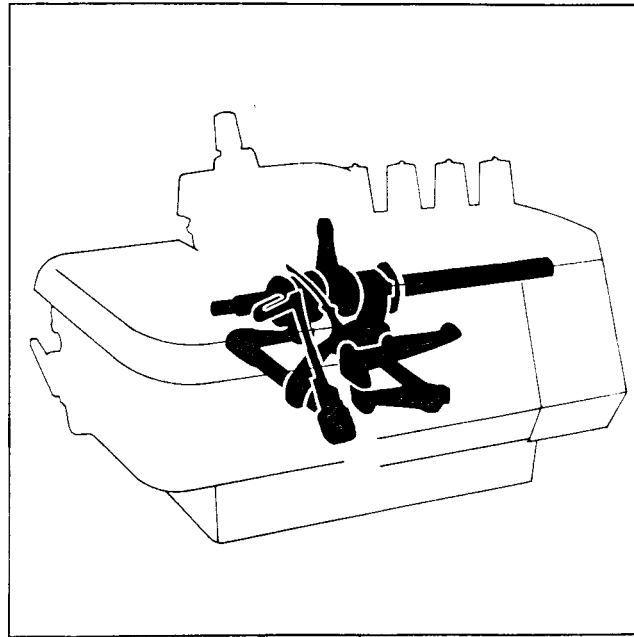

From the library of: Diamond Needle Corp

Parts List for 993BX3 Machine

Ref. No.	Part No. For Ordering	Description	Amt. Req.
1	165303	Feed Bar Hinge Pin (eccentric) Collar with 141292(869)	
2	141292(869)	Feed Bar Hinge Pin (eccentric) Collar Set Screw	
3	165301	Feed Bar Hinge Pin (eccentric) with 141292(869)	
4	141292(869)	Feed Bar Hinge Pin (eccentric) Set Screw	
5	164004	Feed Bar Slide Block (back)	2
6	165305	Feed Bar Hinge Pin (eccentric) Positioning Pin	
7	208(830)	Feed (front) Bar Driving Arm Slide Block Plate Screw	2
8	236(806)	Machine Frame Oil Splash Guard Securing Screw (upper)	
9	107176	Machine Frame Oil Splash Guard (top)	
10	1231(818)	Machine Frame Oil Splash Guard (top) Screw	2
11	350606	Feed (front) Bar Driving Arm Screw	
12	108609	Machine Frame Oil Splash Guard complete	
13	108502	Feed (back) Bar Guide Pin	
14	107970	Feed (back) Bar Guide Bracket	
15	157(830)	Feed (back) Bar Guide Bracket Screw	2
16	141292(869)	Feed (back) Bar Guide Pin Securing Screw	
17	108089	Feed (back) Bar Guide Bracket 107970 with 108502 and two 157(830)	
18	165306	Feed (back) Bar	
19	165326	Feed (front) Bar	
20	108141	Feed (back) and (front) Bars complete Nos. 165135, 165301, 165303, 165305, 165306, 165326 and two 164004	
21	115179	Feed (front) Bar Connection with 165259, 165330 and two 165311	
22	165330	Feed (front) Bar Connection Oil Wick (short)	
23	165259	Feed (front) Bar Connection Oil Wick (long)	
24	165311	Feed (front) Bar Connection Oil Wick Retaining Pin	2
25	141292(869)	Feed Bar Hinge Pin (eccentric) Positioning Pin Set Screw	
26	792(804)	Machine Frame Oil Splash Guard Securing Screw (lower)	
27	9525	Feed (front) Bar Connection Screw Washer	
28	114172(803)	Feed (front) Bar Connection Screw	
29	107829	Feed (front) Bar Wearing Plate	
30	1094(806)	Feed (front) Bar Wearing Plate Screw	
31	165135	Feed Bar Slide Block (front)	
32	107185	Feed Lifting Eccentric	
33	164019	Feed (front) Dog	
34	1454(806)	Feed (front) Dog Screw	
35	164011	Feed (back) Dog Section (left)	
36	108227	Feed (back) Dog Section (right)	
37	1100(830)	Feed (back) Dog Section (right) Screw	
38	108229	Feed (back) Dog complete Nos. 1100(830), 164011 and 108227	
39	1454(806)	Feed (back) Dog Screw	
40	87279	Feed Lifting Eccentric Position Collar with 50150(819)	
41	50150(819)	Feed Lifting Eccentric Position Collar Screw	

From the library of: Diamond Needle Corp

Parts List for 993BX3 Machine

Ref. No.	Part No. For Ordering	Description	Amt. Req.
1	704(809)	Machine Frame Rotary Shaft Bearing (left) Cover Screw	2
2	107953	Machine Frame Rotary Shaft Bearing (left) Cover	
3	108013	Machine Frame Rotary Shaft Bearing (left) Cover Gasket	
4	168(803)	Machine Frame Rotary Shaft Extension Screw	
5	165399	Machine Frame Rotary Shaft Bearing (left)	
6	51145(803)	Feed Eccentric (adjustable) Slide Journal Adjusting Screw	
7	1445(830)	Feed Eccentric (adjustable) Slide Journal Locking Screw	
8	350656(869)	Feed Eccentric (adjustable) Set Screw	2
9	108483	Machine Frame Rotary Shaft Bearing (left) Retaining Ring	
10	165323	Feed Eccentric (adjustable) End Washer	
11	51302(806)	Feed Eccentric (adjustable) End Washer Securing Screw	3
12	108087	Feed Eccentric (adjustable) 1445(803), 51145(803), 165323, two 350656 and three 51302(806)	
13	350606	Feed Driving Arm Clamp Screw	
14	141292(869)	Feed Driving Arm Pin Securing Screw	2
15	115254	Feed Driving Arm with 350606 and two 141292(869)	
16	115256	Feed Driving Arm Pin	
17	1628(809)	Feed Driving Arm Pin Nut	
18	165311	Feed (back) Bar Connection Oil Wick Retaining Pin	
19	165308	Feed (back) Bar Connection 165307 with 165259, 165310 and 165311	
20	165350	Feed Driving Shaft Oil Wick	
21	108232	Feed Driving Shaft Oil Wick Clip	
22	704(819)	Feed Driving Shaft Oil Wick Clip Securing Screw	
23	165349	Feed Driving Shaft Cross Oil Wick	2
24	165351	Feed Driving Shaft Bushing (left)	
25	107827	Feed Driving Shaft Bushing (right)	
26	165347	Feed Driving Shaft	
27	165348	Feed Driving Shaft 165347 with 165350 and two 165349	
28	108160	Feed Driving Shaft Position Collar with two 114224(869)	
29	114224(869)	Feed Driving Shaft Position Collar Set Screw	2
30	115255	Feed (back) Bar Driving Arm with two 51408(830)	
31	51408(830)	Feed (back) Bar Driving Arm Clamping Screw	2
32	165315	Feed (back) Bar Driving Arm Eccentric Stud	
33	1628(809)	Feed (back) Bar Driving Arm Eccentric Stud Nut	
34	17022	Feed (back) Bar Driving Arm Eccentric Stud Nut Washer	
35	115263	Feed (back) Bar Driving Arm 115255 with 1628(809), 17022 and 165315	
36	141420(803)	Feed (back) Bar Connection Screw	
37	131695	Feed (back) Bar Connection Screw Washer	
38	165309	Feed (back) Bar Connection Bushing	
39	165307	Feed (back) Bar Connection	
40	165310	Feed (back) Bar Connection Oil Wick (short)	
41	165259	Feed (back) Bar Connection Oil Wick (long)	
42	108890	Feed Eccentric (adjustable) and Stop Plate complete 108087 with 108891 and two 185(803)	
43	108891	Feed Eccentric (adjustable) Stop Plate with 1735(813) and 50429(830)	
44	185(803)	Feed Eccentric (adjustable) Stop Plate Screw	2
45	50429(830)	Feed Eccentric (adjustable) Stop Screw	
46	1735(813)	Feed Eccentric (adjustable) Stop Screw Nut	

From the library of: Diamond Needle Corp

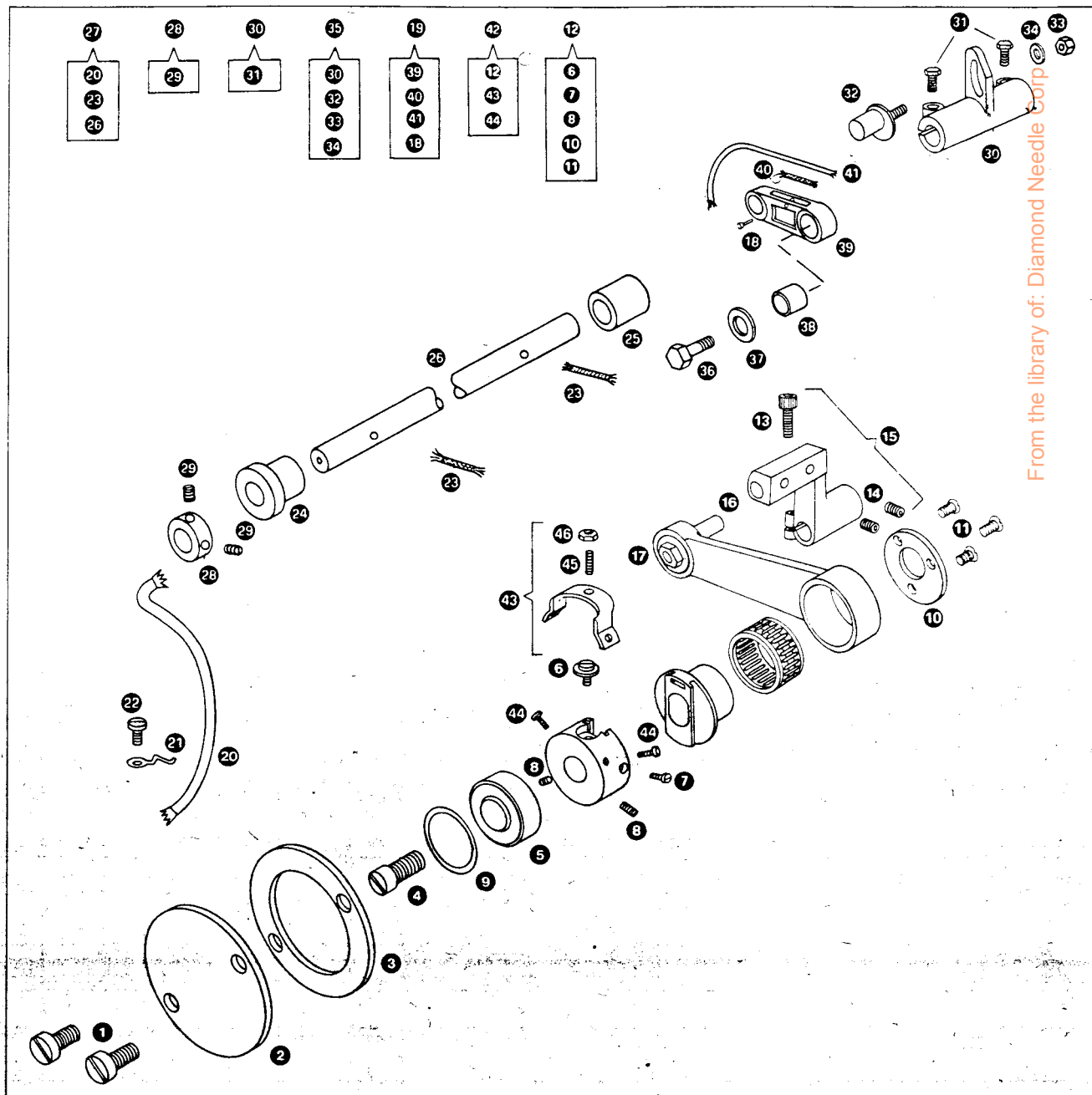
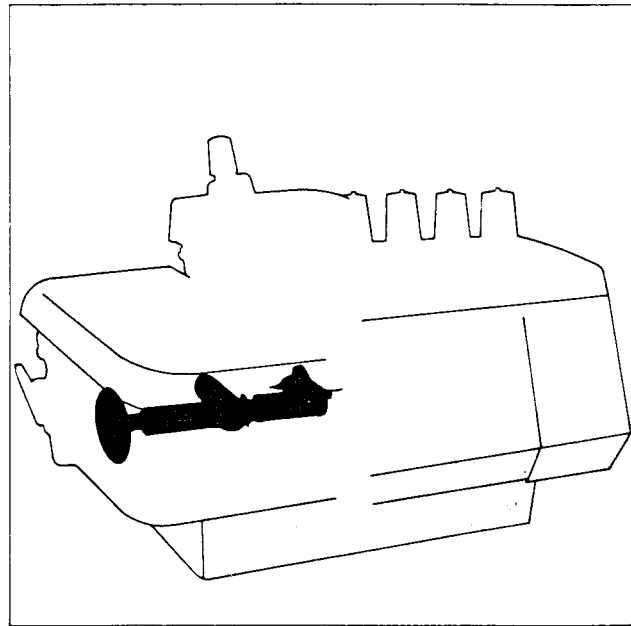

From the library of: Diamond Needle Corp

Parts List for 993BX3 Machine

Ref. No.	Part No. For Ordering	Description	Amt. Req.
1	107161	Presser Bar Bracket	
2	440(830)	Knife (movable) Lever Hinge Stud Set Screw	
3	106466	Knife (movable) Lever Hinge Stud	
4	107575	Knife (movable) Lever with two 141292(869)	
5	141292(869)	Knife (movable) Lever Hinge Pin Screw	2
6	1259(830)	Knife (movable) Lever Bearing and Attachment Bracket Screw	
7	87029	Knife (movable) Lever Bearing and Attachment Bracket	
8	87262	Knife (movable) Lever Bearing and Attachment Bracket 87029 with 1259(830)	
9	447(830)	Knife (movable) Lever Bearing Set Screw (long)	
10	624(830)	Knife (movable) Lever Bearing Set Screw (short)	
11	107192	Knife (movable) Lifting Lever Retaining Washer and Oil Sling	
12	51302(806)	Knife (movable) Eccentric End Washer Securing Screw	2
13	107832	Knife (movable) Lifting Lever with 114224(869)	
14	1628(809)	Knife (movable) Lever Hinge Pin Bearing Lock Nut	
15	107188	Knife (movable) Lever Hinge Pin	
16	108213	Knife (movable) Eccentric End Washer	
17	108071	Knife (movable) Lever 107575 with 1628(809), 106466, 107161, 107188 and 107832	
18	447(830)	Knife (movable) Lever Guide Set Screw	
19	106464	Knife (movable) Lever Guide	
20	106454	Knife (movable) Holder Adjusting Stud Block with 114072	
21	114072	Knife (movable) Holder Screw Stud	
22	106132	Knife (movable) Holder	
23	198(819)	Knife (movable) Holder Screw	
24	164550	Knife (movable)	
25	165487	Knife (movable) Guard (upper)	
26	106452	Knife (movable) Guard (lower)	
27	1628(819)	Knife (movable) Holder Screw Stud Nut	
28	50611(803)	Knife (stationary) Holder Position Screw	2
29	164745	Knife (stationary) Holder Body with two 50611(803)	
30	141444(831)	Knife (stationary) Holder Screw	
31	164043	Knife (stationary) Holder Spring	
32	164525	Knife (stationary) Holder Spring Stud	
33	165062	Knife (stationary) Holder	
34	164728	Knife (stationary)	
35	164744	Knife (stationary) Clamping Gib	
36	114224(869)	Knife (movable) Eccentric Set Screw	
37	114032(832)	Knife (stationary) Clamping Gib Screw	
38	165063	Knife (stationary) Holder (adjustable) complete, Nos. 165062 141444(831) and 164745	
39	165064	Knife (stationary) Holder (adjustable) with Gib complete, Nos. 3146, 114032(832), 165063 and 164744	
40	141004(830)	Knife (stationary) Holder Locking Screw	
41	106472	Knife (stationary) Holder Sleeve	
42	114130	Knife (stationary) Holder Sleeve Stud Set Screw	
43	106471	Knife (stationary) Holder Sleeve Stud	
44	113176	Knife (stationary) Holder Sleeve Stud Lock Nut	
45	3146	Knife (stationary) Clamping Gib Screw Washer	
46	447(830)	Knife (movable) Lever Hinge Stud Set Screw	
47	51302(806)	Knife (movable) Lifting Lever Retaining Washer and Oil Sling Securing Screw	2

From the library of: Diamond Needle Corp

Parts List for 993BX3 Machine

Ref. No.	Part No. For Ordering	Description	Amt. Req.
1	107045	Machine Pulley with two 448(830)	
2	448(830)	Machine Pulley Set Screw	2
3	108445	Oil Pump Cover Oil Seal	
4	108446	Oil Pump Cover Oil Seal Retaining Collar with 141292(869)	
5	114077	Machine Frame Rotary Shaft Screw Stud	
6	107046	Machine Pulley Cap	
7	140416	Machine Pulley Cap Screw	
8	164100	Machine Frame Rotary Shaft Thrust Bearing	
9	139026	Machine Frame Rotary Shaft Ball Bearing	
10	164098	Machine Frame Rotary Shaft Oil Return and Ball Bearing Grease Retainer	
11	107177	Machine Frame Rotary Shaft Ball Bearing Retaining Ring	
12	107034	Machine Frame Rotary Shaft Ball Bearing Housing Gasket	
13	107033	Machine Frame Rotary Shaft Ball Bearing Housing	
14	51369(803)	Machine Frame Rotary Shaft Ball Bearing Housing Screw	4
15	108026	Machine Frame Rotary Shaft Bushing (front)	
16	108598	Oil Pump, complete, Nos. 107064, 107065, 107066, 107067, 107955 and three 1083(805)	
17	448(830)	Oil Pump Body Set Screw	
18	107955	Oil Pump Body with 448(830)	
19	350647(869)	Oil Pump Body Clamping Screw	
20	107065	Oil Pump Drive Pin	
21	107066	Oil Pump Rotor (inner)	
22	107067	Oil Pump Rotor (outer)	
		Note: Nos. 107066 and 107067 must be ordered as a set	
23	107064	Oil Pump Cover	
24	1083(805)	Oil Pump Cover Screw	3
25	141292(869)	Oil Pump Cover Oil Seal Retaining Collar Screw	
26	1036(830)	Machine Frame Rotary Shaft Bushing (front) Set Screw	

Parts List for 993BX3 Machine

Ref. No.	Part No. For Ordering	Description	Amt. Req.
1	114083	Pressure Regulating Thumb Screw	
2	164416	Presser Bar (upright) Spring (heavy)	
	164144	Presser Bar (upright) Spring (can be supplied as an alternative)	
3	107080	Presser Bar Lifting Lever	
4	50073(809)	Knife (movable) Lever and Presser Bar (upright) Housing Screw	2
5	106456(413)	Knife (movable) Lever and Presser Bar (upright) Housing with 460(830)	
6	460(830)	Thread Eyelet (needle thread) Set Screw	
7	114159	Pressure Regulating Thumb Screw Lock Screw	
8	82281	Thread Eyelet (needle thread)	
9	107081	Presser Bar (swing-out) Opening Lever	
10	164143(850)	Presser Bar (upright)	
11	164139	Presser Bar Lifting Lever Spring	
12	114082	Presser Bar (swing-out) Opening Lever Hinge Screw	
13	42436	Presser Bar (swing-out) Opening Lever Hinge Screw Washer	
14	51362(830)	Presser Bar (swing-out) Pivot Screw Locking Plate Screw	
15	140510(819)	Presser Bar (swing-out) Pivot Screw	
16	164351(819)	Presser Bar (swing-out) Pivot Screw Locking Plate	
17	462(830)	Presser Bar Lifting Bracket Set Screw (short)	
18	51846	Presser Bar Lifting Bracket Roller and Stud	
19	624(830)	Presser Bar Lifting Bracket Set Screw (long)	
20	106144	Presser Bar Lifting Bracket with 462(830), 624(830) and 51846	
21	1700(819)	Presser Bar (swing-out) Lifting Screw Stud Nut	
22	164141(850)	Presser Bar (swing-out) Lifting Screw Stud	
23	82330(850)	Presser Bar (swing-out)	
24	107083	Presser Foot complete, Nos. 50169(809), 107082, 50225(809), 164146, 164147 and 164149	
	107082	Presser Foot Body	
	164146	Presser Foot Chaining-off Finger	
	164147	Presser Foot Clamping Plate	
	50225(809)	Presser Foot Clamping Plate Screw	
	164149	Presser Foot Guide	
	50169(809)	Presser Foot Guide Screw	
25	108633	Throat Plate Guide	
26	350680(869)	Throat Plate Guide Screw	2
27	1094(806)	Throat Plate Screw	2
28	108205-008	Throat Plate ($\frac{1}{8}$ inch bight)	
29	106457	Knife (movable) Lever and Presser (upright) Housing, complete Nos. 42436, 82281, 106144, 106456(413), 107080, 107081, 114082, 114083, 114159, 164139, 164143 and 164416	

From the library of: Diamond Needle Corp

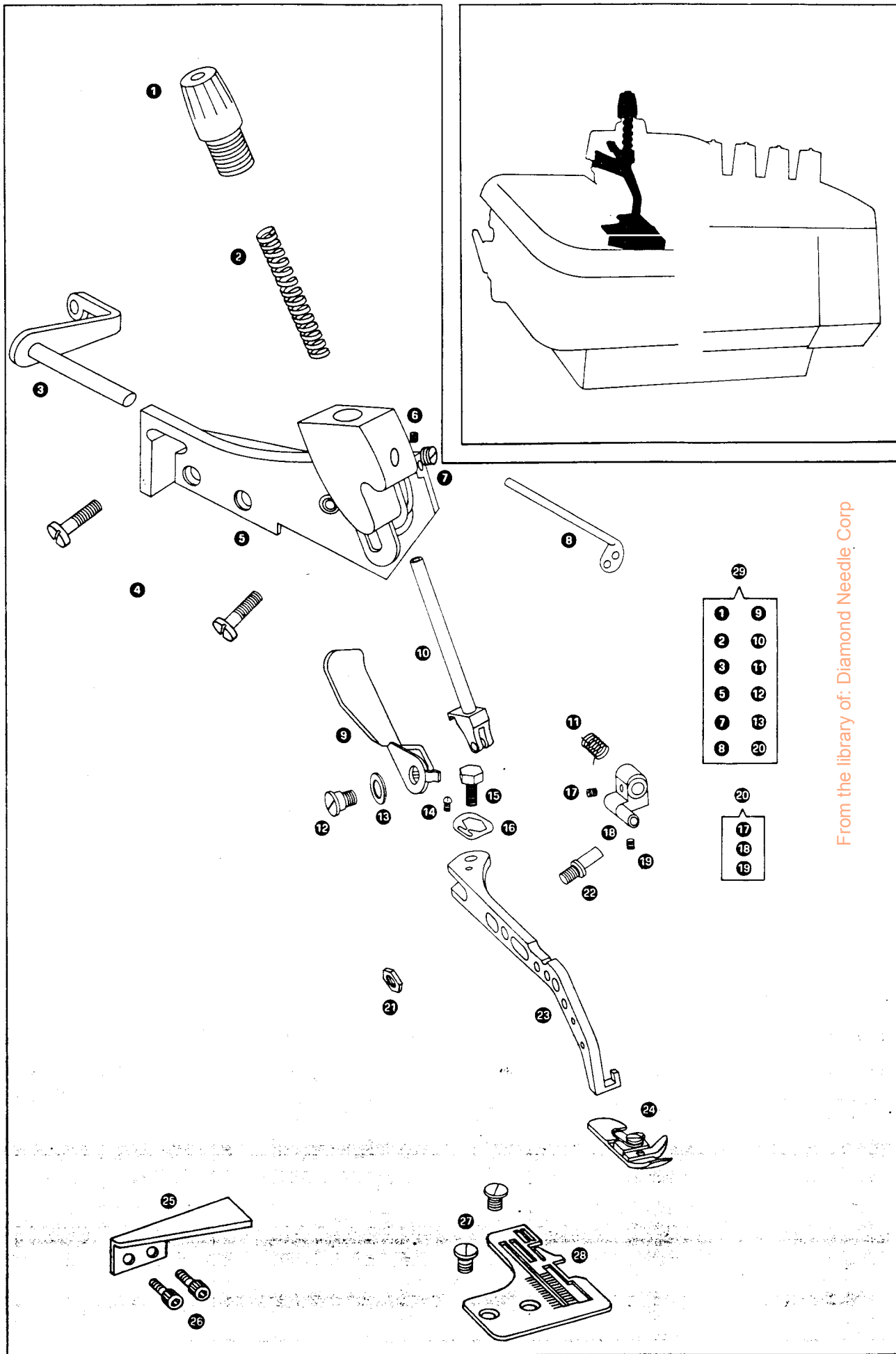

From the library of: Diamond Needle Corp

Parts List for 993BX3 Machine

Ref. No.	Part No. For Ordering	Description	Amt. Req.
1	113191(888)	Tension (light and heavy) Regulating Thumb Nut Lock Nut	3
2	113180(430)	Tension (light) Regulating Thumb Nut (yellow)	
3	113180(431)	Tension (heavy) Regulating Thumb Nut (red)	
4	113180(429)	Tension (heavy) Regulating Thumb Nut (green)	
5	107178	Tension (light and heavy) Spring Bushing	3
6	164157	Tension (light) Spring	
7	107084	Tension (heavy) Spring	2
8	107625	Tension (light and heavy) Spring Cover	3
9	2102	Tension (light and heavy) Disc	6
10	114117(803)	Tension (light and heavy) Screw Stud	3
11	107087	Tension Thread Guide	3
12	931084	Tension (light and heavy) Lock Washer	3
13	1689(809)	Tension (light and heavy) Lock Nut	3
14	107102	Thread (needle) Guide Post	
15	107086(430)	Tension (light) (yellow), complete Nos. 107178, 107625, 113180(430), 113191(888), 114117(803), 164157 and two 2102	
16	107085(431)	Tension (heavy) (red), complete Nos. 107084, 107178, 107625, 113180(431), 113191(888), 114117(803) and two 2102	
17	107085(429)	Tension (heavy) (green), complete Nos. 107084, 107178, 107625, 113180(429), 113191(888), 114117(803) and two 2102	
18	107088	Thread Eyelet (needle thread) Bridge	
19	1423(809)	Thread Eyelet (needle thread) Bridge Securing Screw	
20	109935(830)	Lint Stripper Set Screw	
21	164462	Lint Stripper with 109935(830)	
22	691(803)	Machine Frame Wearing Plate Screw	2
23	82309	Needle Stop Pin	2
24	108818	Needle Carrier with 51768(803), 82312 and 82313	
25	51768(803)	Needle Clamping Nut	
26	82312	Needle Holder	
27	82313	Needle Holder Washer	
28	399(830)	Thread (needle) Controller Screw	2
29	107620	Thread (needle) Controller	
30	108921	Needle Driving Shaft	
31	107839	Needle Driving Shaft Bushing	
32	109876	Needle Driving Shaft Bushing Locating Screw	
33	164053	Needle Driving Shaft Bushing Thrust Washer	
34	Cat. 1431	Needle Size 11	
35	140208(803)	Needle Guard Holder Screw	
36	108632	Needle Guard Holder	
37	50025(809)	Needle Guard Set Screw	
38	165058	Needle Guard	
39	165406	Machine Frame Wearing Plate	
—	107040	Machine Frame Top Cover Assembly, Nos. 107085(429), 107085(431), 107086(430), 107102, 228661, two 107090 and three each 1700(809), 107087 and 931084	
40	350719(869)	Needle Carrier Clamping Screw	
41	108604	Machine Frame Closing Plate (front)	
42	1238(806)	Machine Frame Closing Plate (front) Set Screw	3

From the library of: Diamond Needle Corp

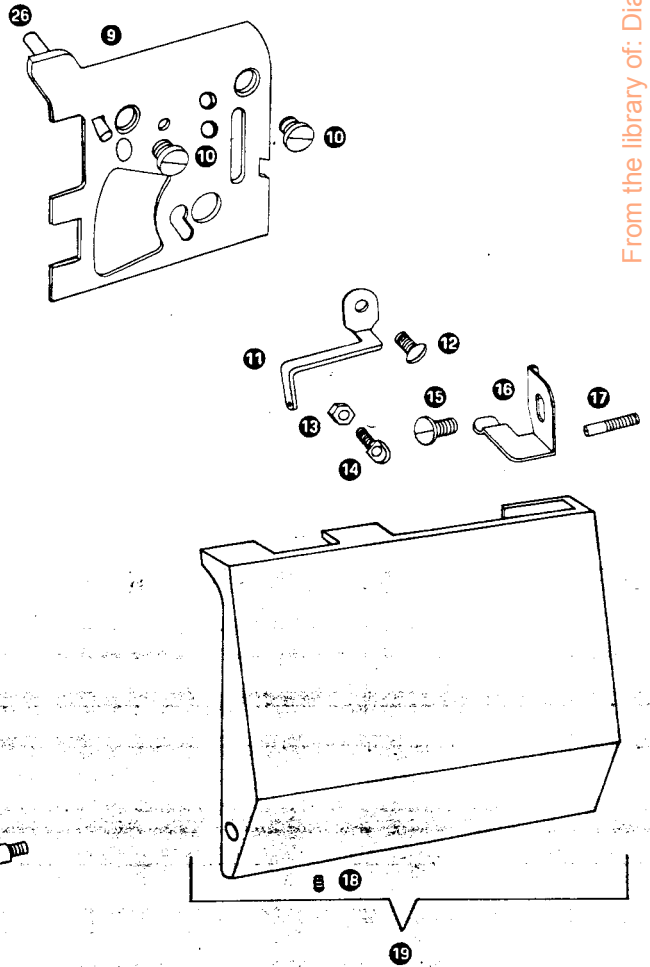
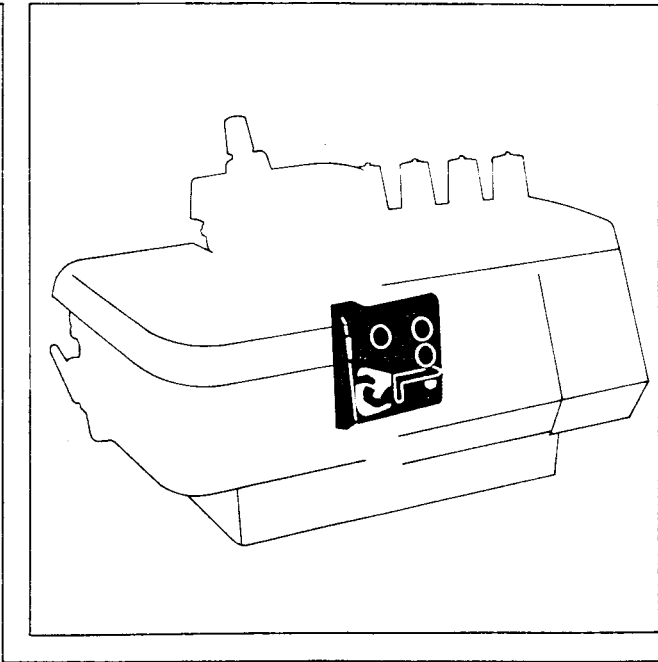
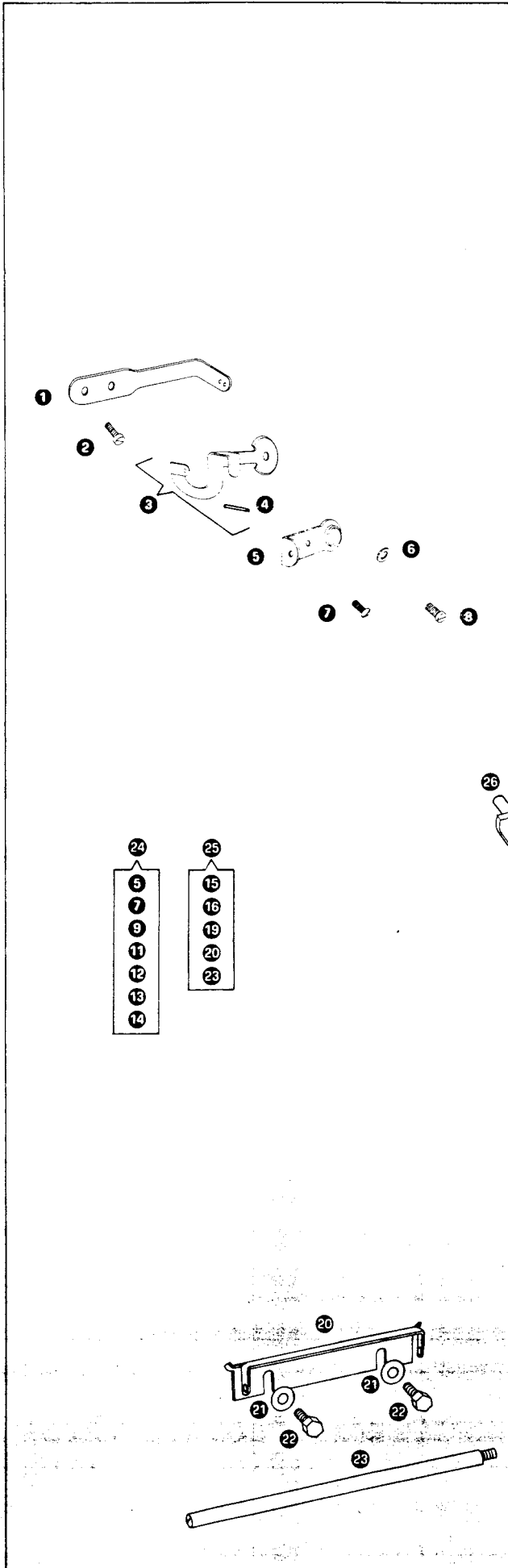

From the library of: Diamond Needle Corp

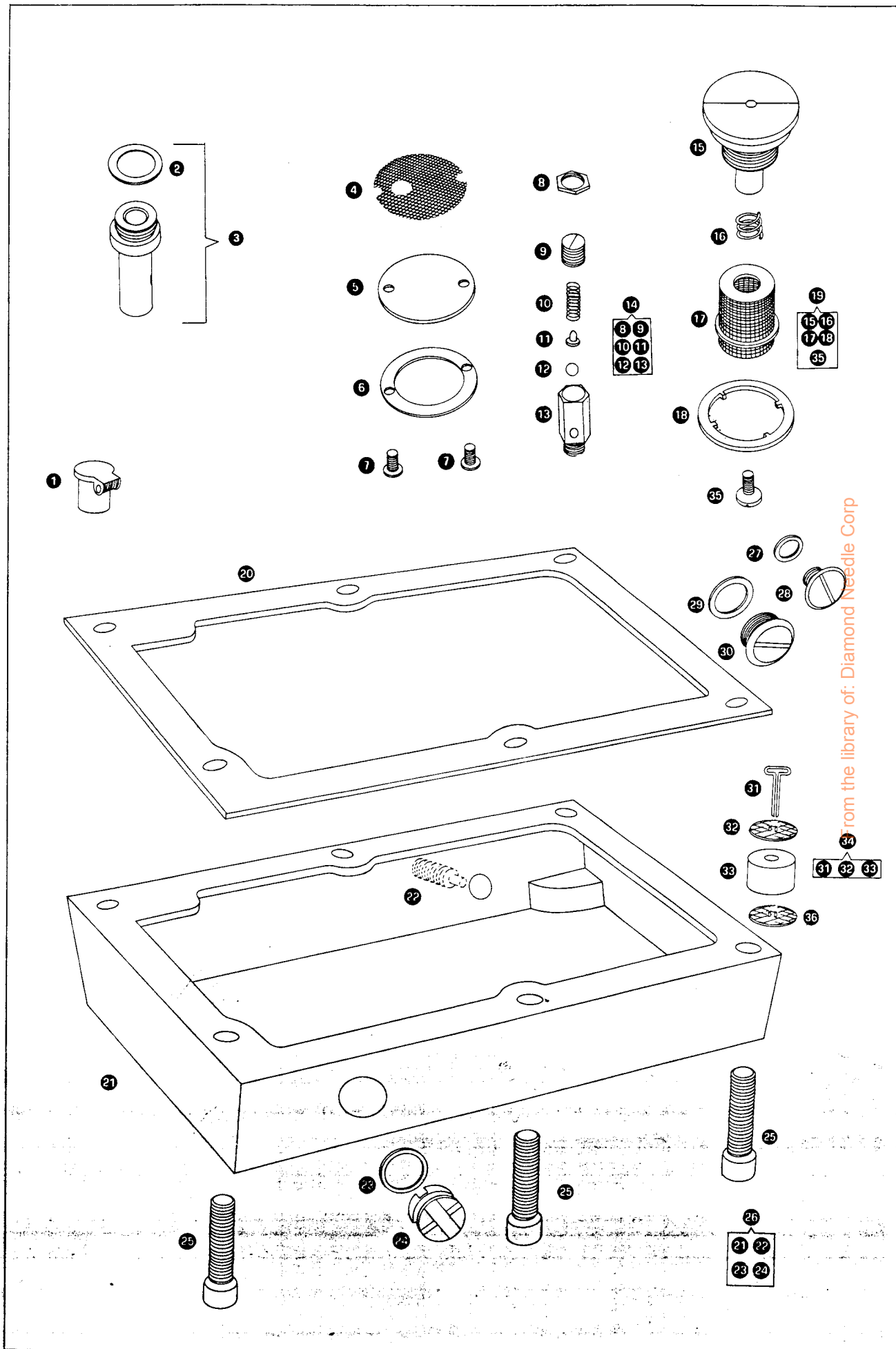

From the library of: Diamond Needle Corp

Parts List for 993BX3 Machine

Ref. No.	Part No. For Ordering	Description	Amt. Req.
1	704(892)	Machine Frame Closing Plate (rear) Screw	6
2	107954	Machine Frame Closing Plate (rear)	
3	108228	Machine Frame Closing Plate (rear) Gasket	
4	108630	Machine Frame Oil Seal	
5	1094	Machine Frame Oil Splash Cover (top) Securing Screw	3
6	108607	Machine Frame Oil Splash Cover (top) with 108608	
7	108373	Machine Frame Oil Splash Cover (top) Access Plug	
8	108608	Machine Frame Oil Splash Cover (top) Gasket	
9	108214	Machine Frame Oil Splash Seal Support	
10	1443(809)	Machine Frame Oil Splash Seal Support Securing Screw	
11	50073(809)	Machine Frame Top Cover Screw	2
12	107039	Machine Frame Top Cover with two 107090	
13	107090	Looper (left hand) Thread Tube (upper)	
14	107090	Thread (looper, right hand) Tube (upper)	
15	108600	Cloth Plate	
16	125399	Cloth Plate Hinge Stud Friction Washer	
17	165290	Cloth Plate Position Collar with two 114224(869)	
18	39541	Cloth Plate Hinge Stud Washer	
19	1209(809)	Cloth Plate Hinge Stud Washer Retaining Screw	
20	114224(869)	Cloth Plate Position Collar Set Screw	2
21	237(809)	Cloth Plate Lock Spring Screw	2
22	165287	Cloth Plate Lock Spring	
23	107098	Cloth Plate Lock Spring Retaining Screw Stud	
24	1700(809)	Cloth Plate Position Bracket Screw Nut	
25	51408(832)	Cloth Plate Position Bracket Screw	
26	108601	Cloth Plate, complete Nos. 1700(809), 51408(832), 108600, 165287 and two 237(809)	
27	228661	Machine Frame Top Cover Tension Screw Hole Plug	
28	109898(832)	Presser Bar Lifting Lever Stop Screw	
29	1637(810)	Presser Bar Lifting Lever Stop Screw Nut	
30	106458(413)	Knife (movable) Lever and Presser Bar (upright) Housing Cover (hinged)	
31	114073	Knife (movable) Lever and Presser Bar (upright) Housing Cover Hinge Bracket Screw	2
32	108436(869)	Knife (movable) Lever and Presser Bar (upright) Housing Cover Hinge Screw Locking Screw	
33	106460	Knife (movable) Lever and Presser Bar (upright) Housing Cover Hinge Pin	
34	106459(413)	Knife (movable) Lever and Presser Bar (upright) Housing Cover Hinge Bracket	
35	114082(819)	Knife (movable) Lever and Presser Bar (upright) Housing Cover Stop Plate Screw	2
36	42436	Knife (movable) Lever and Presser Bar (upright) Housing Cover Stop Plate Screw Washer (quantity as required)	
37	106463	Knife (movable) Lever and Presser Bar (upright) Housing Cover Stop Plate	
38	107042	Machine Frame Top Cover Closing Plate with 107059	
39	1094(850)	Machine Frame Top Cover Closing Plate Screw	8
40	106461	Knife (movable) Lever and Presser Bar (upright) Housing Cover Latch Spring	
41	227(819)	Knife (movable) Lever and Presser Bar (upright) Housing Cover Latch Spring Screw	
42	106462	Knife (movable) Lever and Presser Bar (upright) Housing Cover Latch Spring Pin	
43	113176(819)	Knife (movable) Lever and Presser Bar (upright) Housing Cover Latch Spring Pin Lock Nut	
44	107059	Oil Flow Indicator	
45	107060	Oil Flow Indicator Nozzle	
46	107044	Machine Frame Top Cover Closing Plate Gasket	
47	114142(809)	Belt Cover Screw	2
48	106430	Belt Cover	
49	108606	Machine Frame Front Cover	2
50	1238(892)	Machine Frame Front Cover Screw	2
51	108619	Chip Guard complete	
52	140509(809)	Chip Guard Screw (upper)	
53	1209(800)	Chip Guard Screw (lower)	

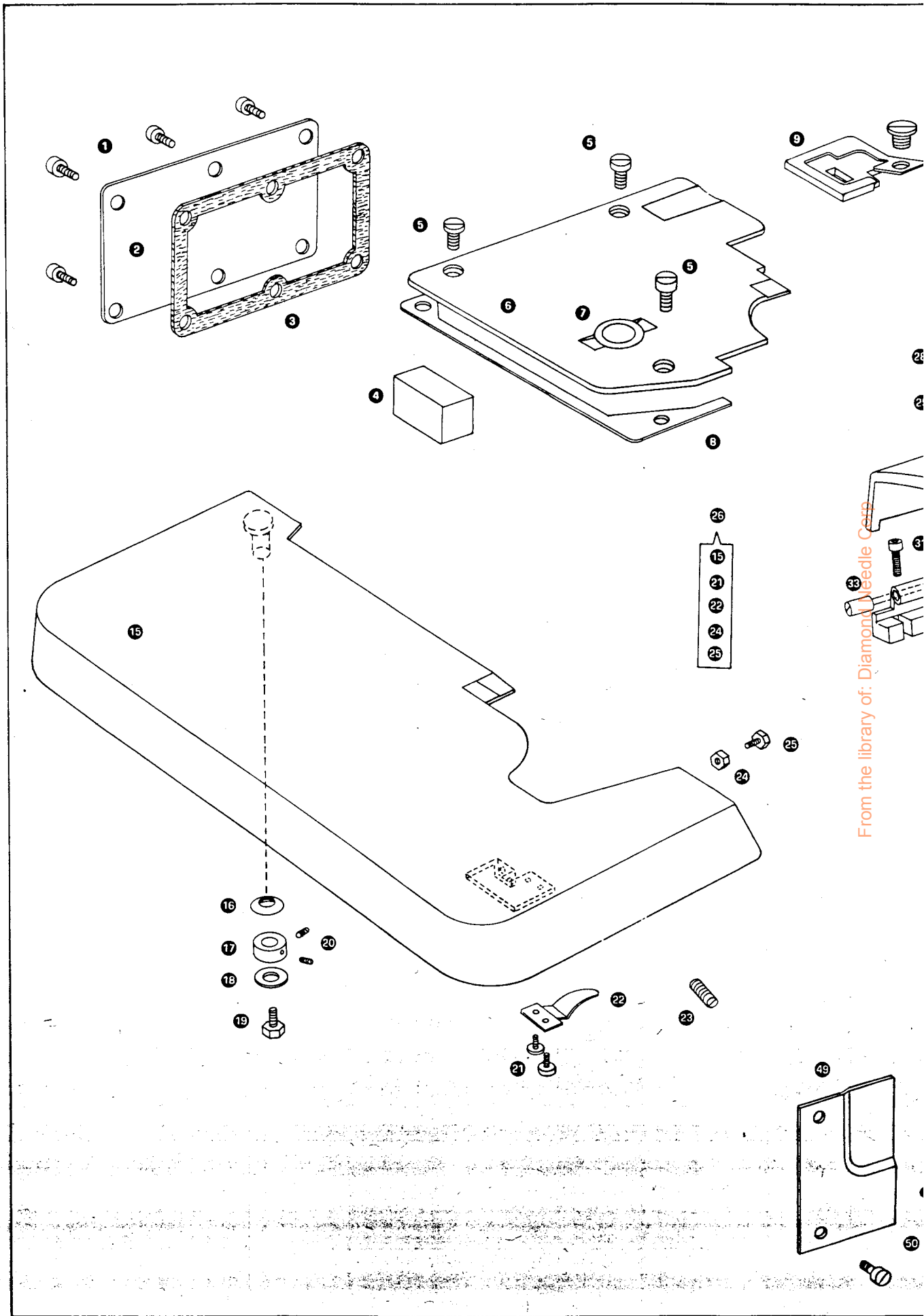

From the library of: Diamond Needle Corp

SUPPLIED WITH MACHINE

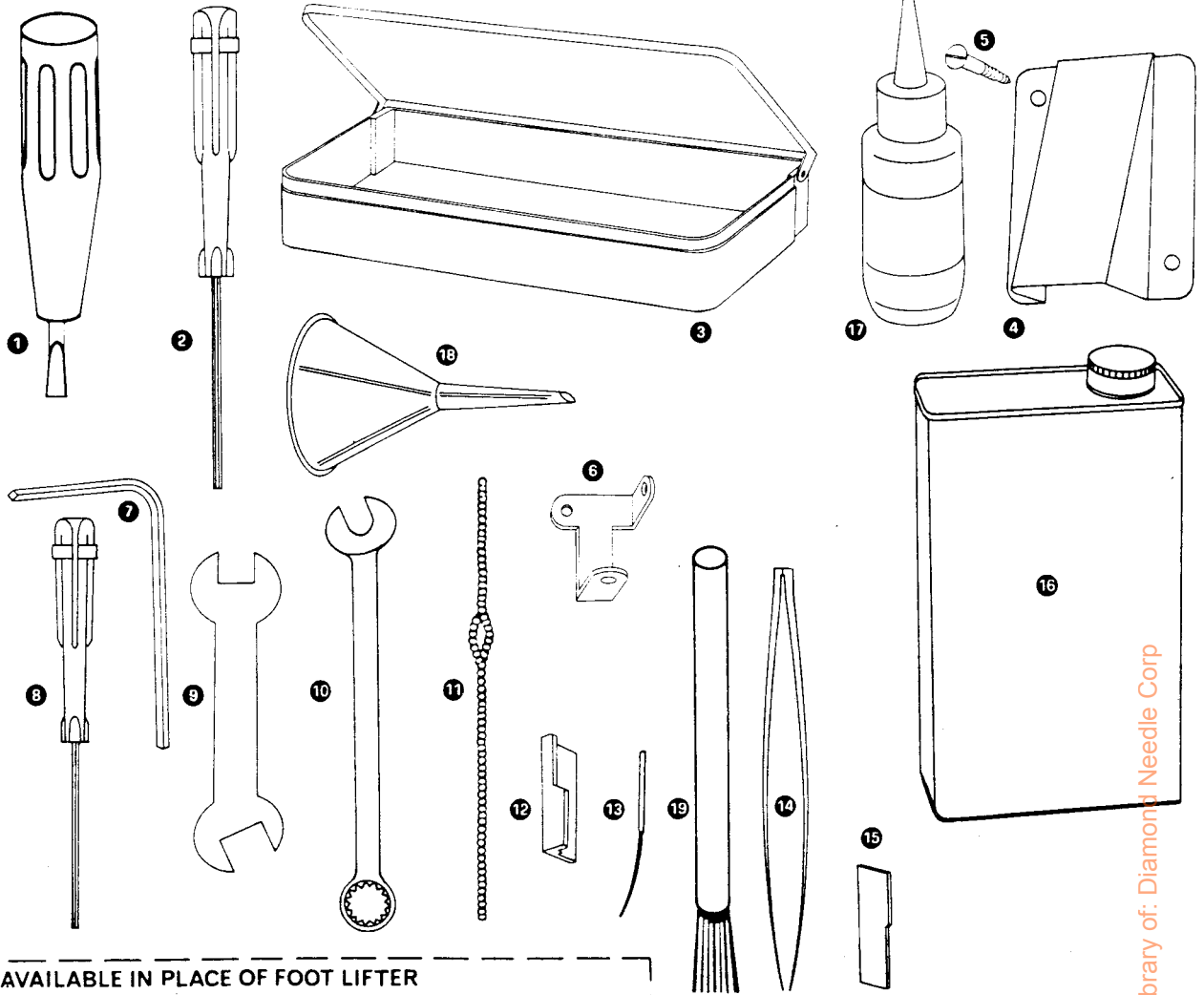

AVAILABLE IN PLACE OF FOOT LIFTER

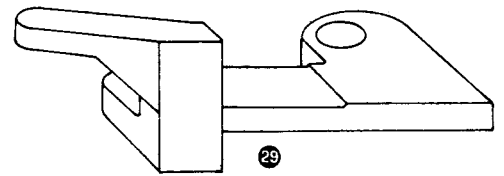
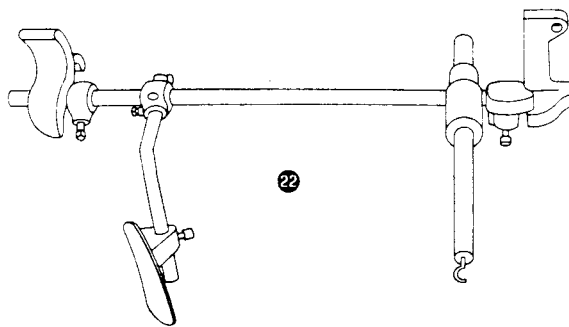

AVAILABLE AT EXTRA CHARGE

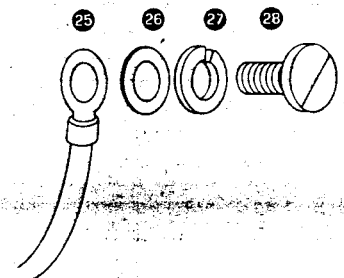
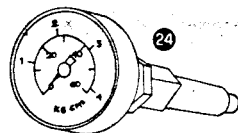

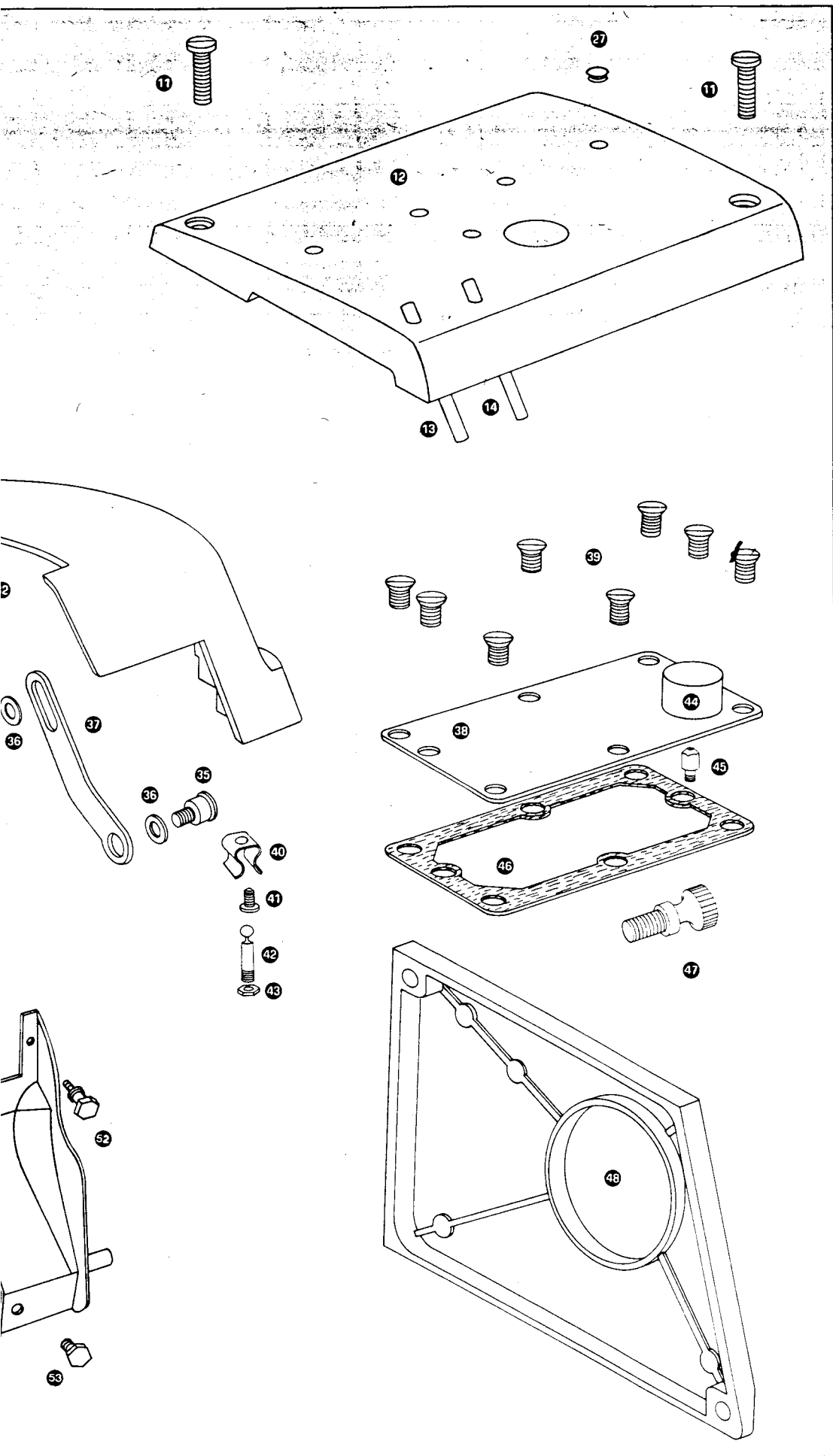

Parts List for 993 Machines—Accessories

Ref. No.	Part No. For Ordering	Description	Amt. Req.
Supplied with Machine			
1	161294	Screw Driver (plastic handle) (large)	
2	108115	Wrench 1/16 inch (plastic handle)	
3	108148	Accessory Box (plastic)	
4	108123	Belt Cover (rear)	
5	—	Belt Cover (rear) Wood Screw 3/8 inch (10mm) No. 6 R.H.	4
6	164164	Thread (looper, right hand) Thread Eyelet (movable)	
7	820193-002	Wrench for 1/16 inch (1.6mm) socket head screw	
	820193-003	Wrench for 5/64 inch (2mm) socket head screw	
	820193-005	Wrench for 1/8 inch (3.2mm) socket head screw	
	108452	Wrench for 5/32 inch (4mm) socket head screw	
	820193-007	Wrench for 3/16 inch (4.8mm) socket head screw	
	820193-009	Wrench for 3/32 inch (2.4mm) socket head screw	
	820193-010	Wrench for 7/32 inch (5.6mm) socket head screw	
8	108146	Allen Wrench 3/32 inch (2.4mm) (with plastic handle)	
9	10875	Wrench (flat)	
10	108777	Combination Wrench	
11	164196	Threader	6
12	164550	Knife (movable)	
13	Cat. 1431	Needles, size 11 (or according to fittings being supplied)	12
14	108057	Tweezers	
15	164728	Knife (stationary)	
16	81350-011	Tin of Oil (500ml type "H" Oil)	
17	108065	Oil Dispenser	
18	108147	Oil Funnel	
19	107627	Lint Brush	
20	81443	Thread Unwinder (3 spools)	
21	81444	Thread Unwinder (4 spools)	
22	164727	Knee Lifter (supplied in place of Foot Lifter if requested)	
Available at an Extra Charge			
23	82253	Gauge	
	108058	Dust Cover (not illustrated)	
24	107936	Oil Pressure Gauge	
25	108224	Earthing Wire	
26	49109	Earthing Wire Washer	
27	701679	Earthing Wire Screw Washer	
28	176(809)	Earthing Wire Screw	
29	108592	Looper (left hand) Gauge	
Special Tools to allow Agencies to fit Oil Pump assemblies			
—	115182-982	Line Reamer	
—	115183-982	Line Reamer Guide Bush (large)	
Other Tools available			
	108456-982	Ball Bearing Extractor complete	
	108461-982	Ball Bearing Replacement Fixture complete	
	108462-982	Ball Bearing Replacement Sleeve	
	108463-982	Ball Bearing Housing Replacement Sleeve	
	108464-982	Oil Pump Cover Centralising Sleeve	
	115328-982	Ball Bearing (left hand end) Replacement Tool complete	

Parts List for 993 Machines—Accessories

Ref. No.	Part No. For Ordering	Description	Am... Req.
Available at an Extra Charge			
1	1700(809)	Chip Chute Support Bracket Screw Nut	4
2	175032	Chip Chute Support Bracket Screw Washer	4
3	107156	Chip Chute Support Bracket (left hand)	
4	1094(809)	Chip Chute Support Bracket Screw	4
5	107157	Chip Chute Support Bracket (right hand)	
6	107105	Chip Chute (long)	
	or		
	108217	Chip Chute (short)	
7	107514	Chip Chute Sleeve	
8	107989	Chip Chute (long) complete, Nos. 107105, 107156, 107157, 107514, four each 1094(809), 1700(809) and 175032	
	or		
	108219	Chip Chute (short) complete, Nos. 107156, 107157, 107514, 108217, four each 1094(809), 1700(809) and 175032	
Supplied with Machine			
9	51797	Machine Base Mounting Screw Insert	4
10	9842	Machine Base Mounting Screw Washer	4
11	350647(869)	Machine Base Mounting Screw	4
12	81231	Machine Cushion (large)	2
13	164189	Machine Cushion (small)	2
14	108220	Machine Base Support Tube End Plug	2
15	9525	Chip Chute Support Bracket (left hand) Screw (upper) Washer	
16	114116	Chip Chute Support Bracket (left hand) Screw (upper)	
17	(107107) 115465	Machine Base complete with 20437, 114116, two each 81231, 108220, 164189, four each 9842, 51797 and 350647(869)	

AVAILABLE AT AN EXTRA CHARGE

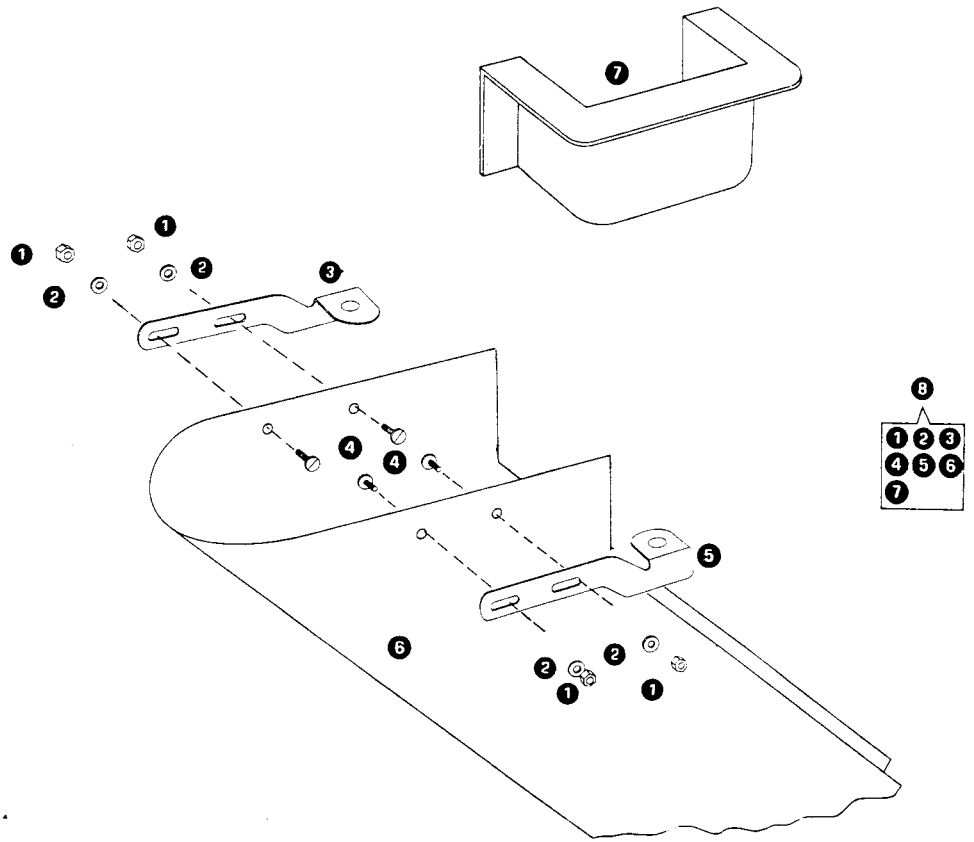

SUPPLIED WITH MACHINE

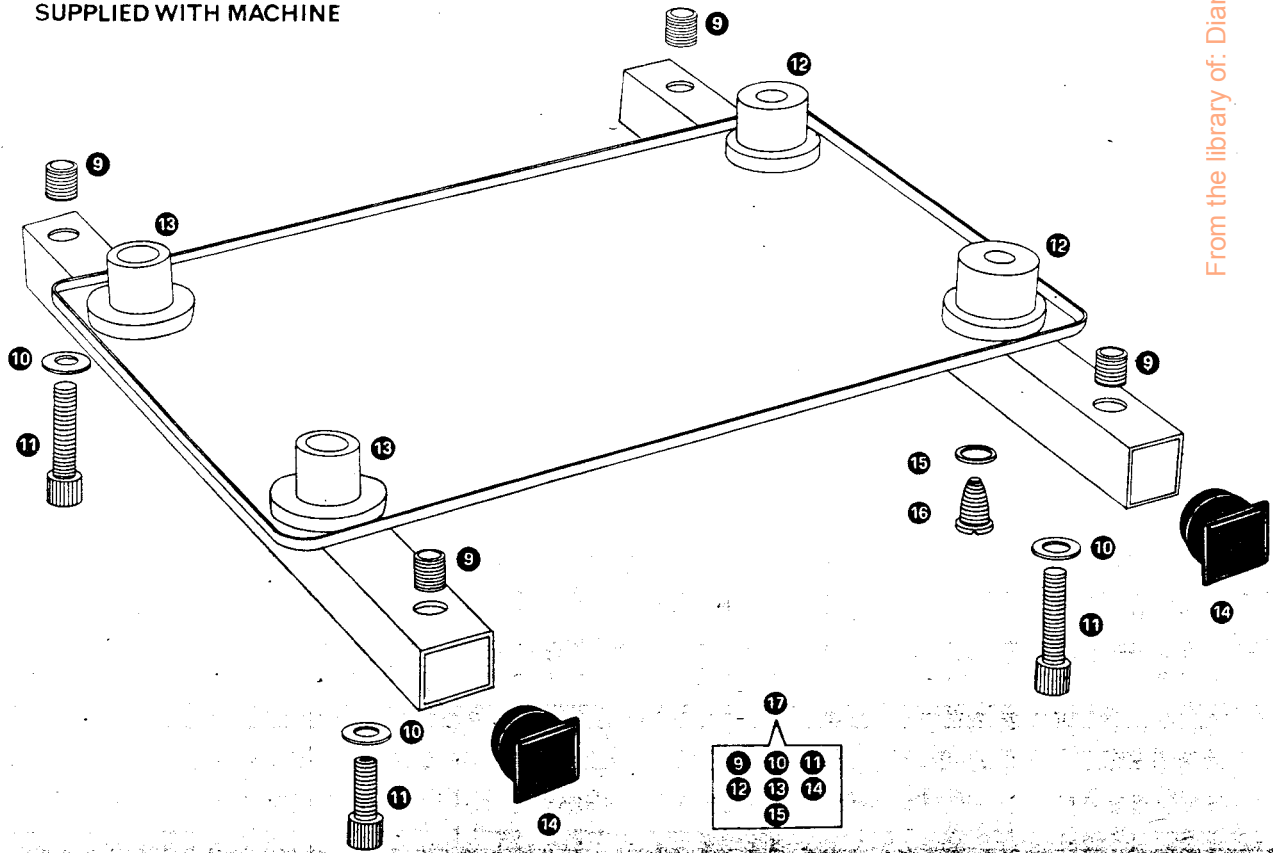

From the library of: Diamond Needle Corp

Parts List for 993 Machines—Accessories

Ref. No.	Part No. For Ordering	Description	Amt. Req.
Supplied with Machine			
1	107501	Foot Lifter Operating Cable	
2	140393	Foot Lifter Operating Cable Retaining Collar Screw	
3	107505	Foot Lifter Operating Cable Retaining Collar with 140393	
4	107513	Foot Lifter Operating Cable complete, Nos. 107501 and 107505	
5	164042	Foot Lifter Operating Cable Friction Sleeve	

Listed below are foot treadles suitable for floor mounting, mounting to the round cross brace of a stand, or mounting to the flat pressed steel treadle support of a stand. The customer is required to specify which treadle, if any, he requires and it will be supplied at no charge.

Treadle for Floor Mounting

6	152168	Treadle	
7	115420	Treadle 152168 with 51723, 115418, 152171 and 67425	
8	107626	Treadle 115420 with two 107502 and four wood screws 3/4 inch (19mm) No. 12 R.H.	
9	115418	Treadle Extension	
10	152171	Treadle Extension Swivel Stud	
11	51723	Treadle Extension Wing Nut	
12	67425	Treadle Extension Wing Nut Lock Washer	
13	107502	Treadle Hinge Bracket	2
14	—	Treadle Hinge Bracket Wood Screw 3/4 inch (19mm) No. 12 R.H.	4

Treadle for Mounting to Round Cross Brace

6	152168	Treadle	
7	115420	Treadle 152168 with 51723, 115418, 152171 and 67425	
19	115421	Treadle 115418 with 152153 and two 152080	
9	115418	Treadle Extension	
10	152171	Treadle Extension Swivel Stud	
11	51723	Treadle Extension Wing Nut	
12	67425	Treadle Extension Wing Nut Lock Washer	
15	152080	Treadle Position Collar with 51089	2
16	51089	Treadle Position Collar Bolt with 51581	2
17	51581	Treadle Position Collar Bolt Nut	2
18	152153	Treadle Spring	

Treadle for Mounting to Flat Pressed Steel Treadle Support

6	152168	Treadle	
7	115420	Treadle 152168 with 51723, 115418, 152171 and 67425	
26	107546	Treadle 115420 with two 107512	
9	115418	Treadle Extension	
10	152171	Treadle Extension Swivel Stud	
11	51723	Treadle Extension Wing Nut	
12	67425	Treadle Extension Wing Nut Lock Washer	
13	107502	Treadle Hinge Bracket	
25	107512	Treadle Hinge Bracket 107502 with two each 23250, 51082-002 and 67425	
20	141223-002	Treadle Hinge Bracket Bolt	
21	51082-002	Treadle Hinge Bracket Bolt 141223-002 with 51581	
22	51581	Treadle Hinge Bracket Bolt Nut	
23	67425	Treadle Hinge Bracket Bolt Nut Lock Washer	
24	23250	Treadle Hinge Bracket Bolt Washer	

Available at an extra charge

For use with table mounted motors and Series 52, 53 motors

27	108221	Presser Bar Lifter Connecting Cable	
28	108222	Presser Bar Lifter Operating Arm	
29	5599	Presser Bar Lifter Operating Arm Bracket	
30	5601	Presser Bar Lifter Operating Arm Hinge Pin	
31	—	Presser Bar Lifter Operating Arm Bracket Wood Screw 3/4 inch (19mm) No. 6 R.H.	2
32	108223	Presser Bar Lifter Operating Arm complete, Nos. 5599, 5601, 108221, 108222 and two 8905 and Wood Screws 3/4 inch (19mm) No. 6 R.H.	
Not illustrated :-	8905	Presser Bar Lifter Operating Arm Bracket Washer	2

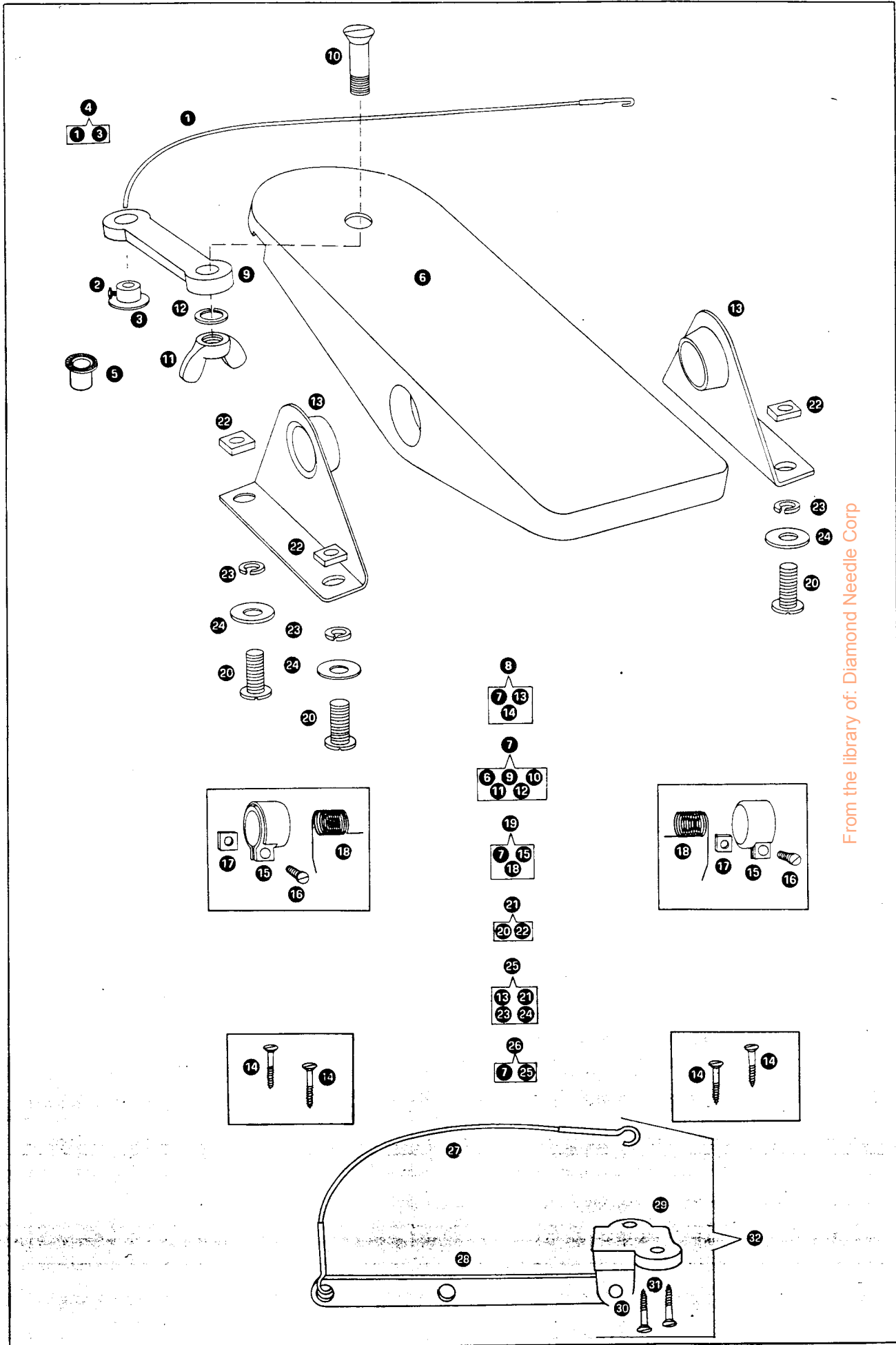

From the library of: Diamond Needle Corp

Parts List for 993 Machines—Accessories

Ref. No.	Part No. For Ordering	Description	Amt. Req.
1	151027	Thread Guide (lower) Support with 50311 (803)	
2	453(830)	Thread Guide Rod Set Screw	
3	151162	Thread Guide (upper, solid)	
4	453(830)	Thread Guide Set Screw	
5	151029	Thread Guide (upper) Holder with four 453(830)	
6	151028	Thread Guide (upper, hollow)	
7	151030(809)	Thread Guide Rod	
8	151026	Thread Guide (lower)	
9	50311(803)	Thread Guide (lower) Holder Set Screw	
10	228692	Spool Pin	4
11	201018(803)	Spool Rest Set Screw	
12	858(830)	Spool Rest Hub Set Screw	
13	225259	Spool Rest with 82538, 201018(803), 201528(819) and 228692 (one spool)	
14	150203	Spool Rest Cushion (felt)	4
15	151024	Spool Rest Rod	
16	151023	Spool Rest with 858(830), three each 82538, 201528(819) and 228692 (three spools)	
17	1122(803)	Spool Rest Rod Set Screw	2
18	151025	Spool Rest Stand with two 1122(803) and three wood screws 1 inch No. 12 F.H.	
19	101921	Thread Guide (lower)	
20	165148	Thread Guide (lower) Holder with two 172(809)	
21	172(809)	Thread Guide (lower) Holder Screw	2
22	81444	Thread Unwinder, complete	
23	201528(819)	Spool Pin Nut	4
24	82538	Spool Pin Washer	4

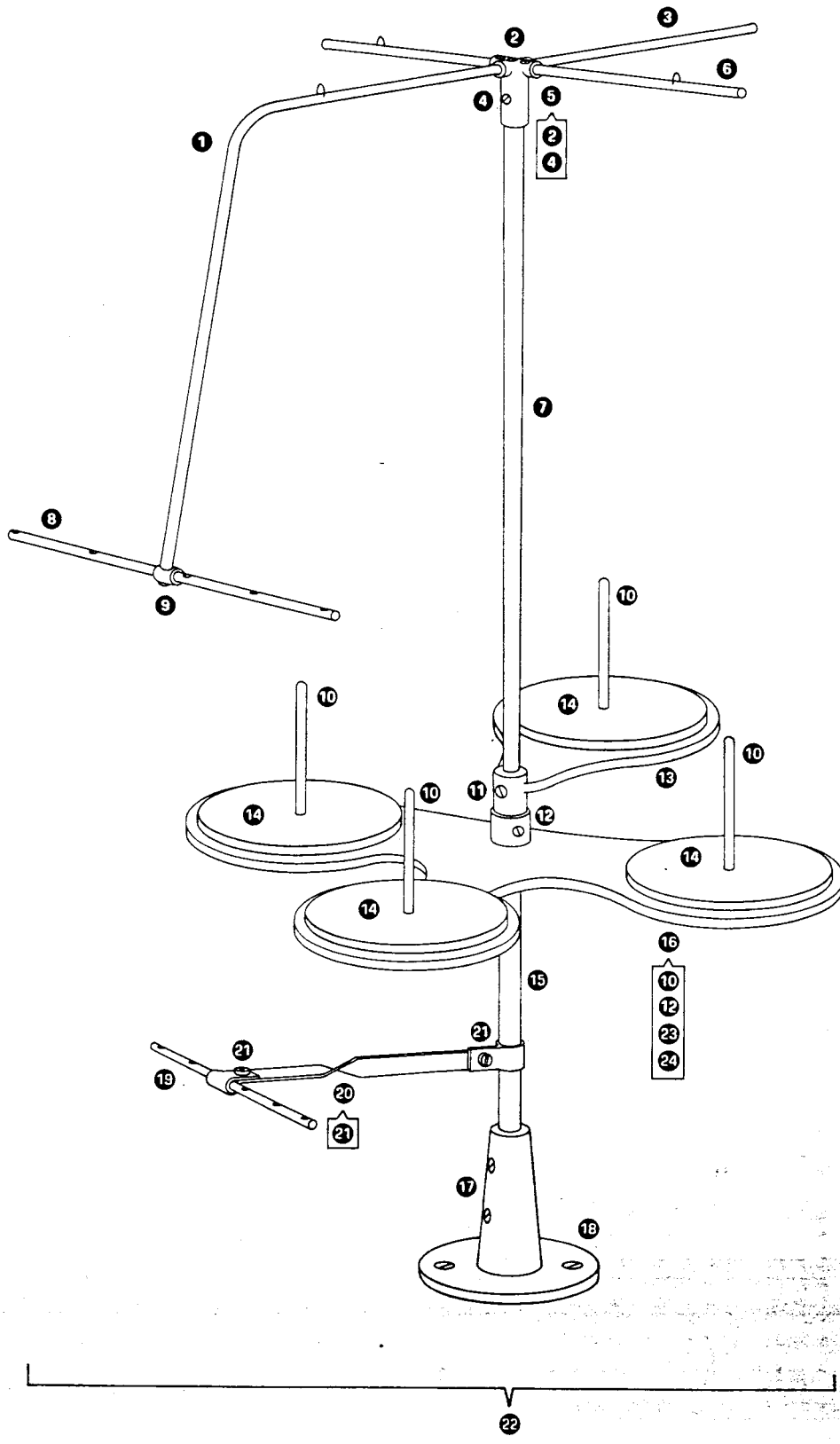

List of Parts for 993B3, 993BX10 and 993B10 Machine Varieties

Parts listed for the undernoted varieties are the same as the 993BX3 Machine with the following exceptions.
(Continued on page 82)

993BX3 Part No.	993B3 Ref. Part No. No.	993BX10 Ref. Part No. No.	993B10 Ref. Part No. No.	Description
107045	1 108765	107045	1 108765	Machine Pulley with two 448(830)
107046	2 108766	107046	2 108766	Machine Pulley Cap
—	—	3 665(809)	3 665(809)	Chain Cutter Knife Screw
—	—	4 164861	4 164861	Chain Cutter Knife
—	—	5 164863	5 164863	Chain Cutter Holder
—	—	6 164864	6 164864	Chain Cutter Chain Retainer Spring
—	—	7 665(809)	7 665(809)	Chain Cutter Chain Retainer Spring Screw
—	—	8 164865	8 164865	Chain Cutter with Chain Retainer complete 164861, 164863, 164864 and two 665(809)
108818	108818	9 108941	9 108941	Needle Carrier
Cat. 1431	Cat. 1431	10 Cat. 1435	10 Cat. 1435	Needle
165058	165058	11 108112	11 108112	Needle Guard
107083	107083	12 164627	12 164627	Presser Foot complete
108205-008	108205-008	13 101948	13 101948	Throat Plate
108633	108633	14 108661	14 108661	Throat Plate Guide
108229	108229	15 164617	15 164617	Feed (back) Dog complete
164019	164019	16 165108	16 165108	Feed (front) Dog
108601	108601	17 108660	17 108660	Cloth Plate complete
108617	108780	108663	108782	Thread (looper) Plate Cover assembly
108616(413)	108779	108635	108781	Thread (looper) Plate Cover with 109927(869)
108600	108600	108659	108659	Cloth Plate
107040	107040	107944	107944	Machine Frame Top Cover Assembly
228661	228661	—	—	Machine Frame Top Cover Tension Screw Hole Plug
—	—	113180(624)	113180(624)	Tension (heavy) Regulating Thumb Nut (blue)
—	—	107085(624)	107085(624)	Tension (heavy) complete (blue)
106430	108783	106430	108783	Belt Cover
165062	18 115140	165062	18 115140	Knife (stationary) Holder
165063	115141	165063	115141	Knife (stationary) Holder (adjustable) complete
165064	115142	165064	115142	Knife (stationary) Holder (adjustable) with Gib (complete)

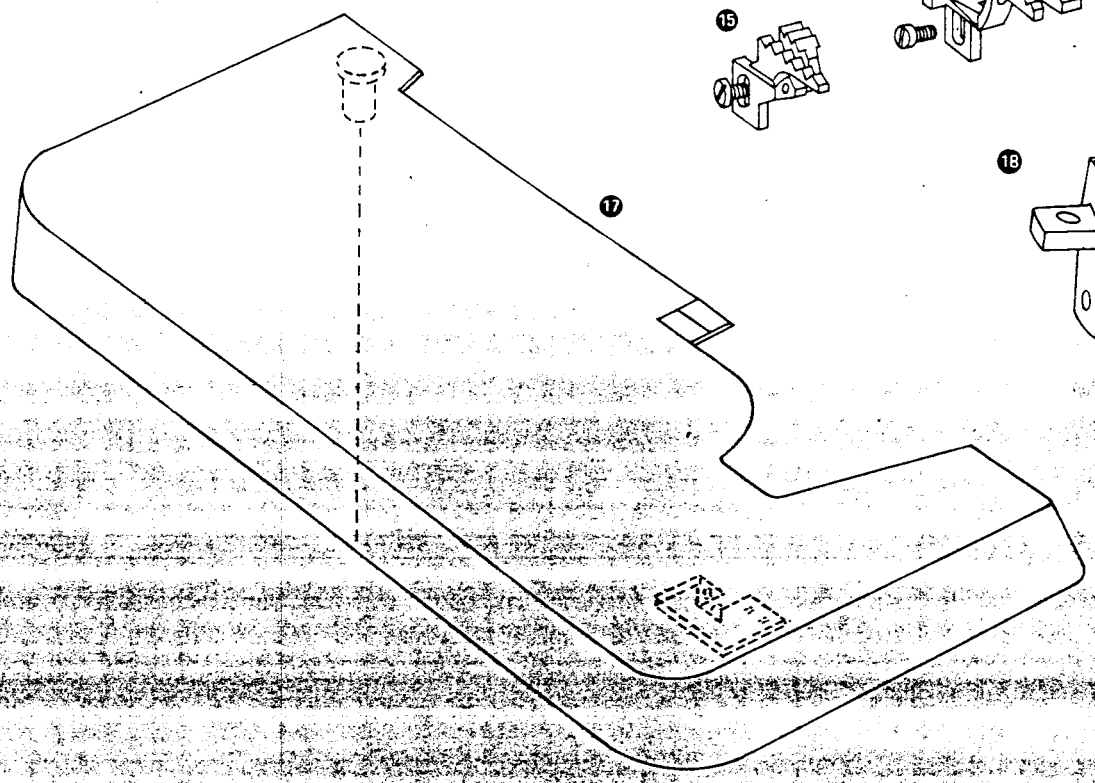
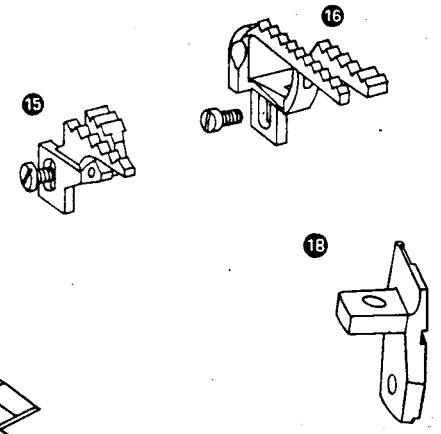
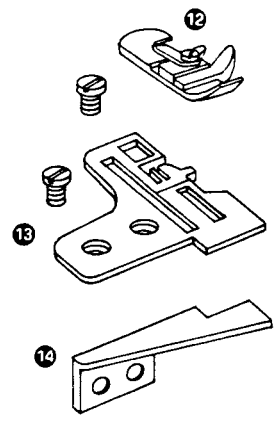
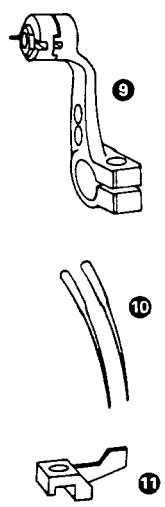
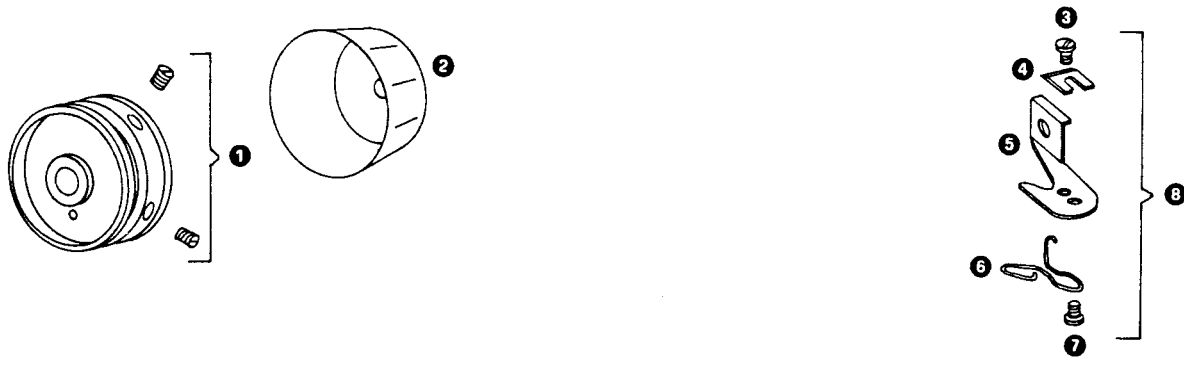

From the library of: Diamond Needle Corp

List of Parts for 993B3, 993BX10 and 993B10 Machine Varieties

Parts List for the undernoted varieties are the same as the 993BX3 machine with the following exceptions.

(Continued from page 80)

993BX3	993B3	993BX10	993B10	Description
Ref. Part No. No.	Ref. Part No. No.	Ref. Part No. No.	Ref. Part No. No.	
—	1 87279	—	1 87279	Feed Eccentric (adjustable) Disc Position Collar with 50150(819)
—	2 50150(819)	—	2 50150(819)	Feed Eccentric (adjustable) Disc Position Collar Set Screw
—	3 108757	—	3 108757	Feed Eccentric (adjustable) Disc Spring
—	4 108755	—	4 108755	Feed Eccentric (adjustable) complete
—	5 435(830)	—	5 435(830)	Feed Eccentric (adjustable) Set Screw
—	6 108753	—	6 108753	Feed Eccentric (adjustable) Body
—	7 114200(830)	—	7 114200(830)	Feed Eccentric (adjustable) Stop Screw
—	8 114201(869)	—	8 114201(869)	Feed Eccentric (adjustable) Stop Screw Set Screw
—	9 468(830)	—	9 468(830)	Feed Eccentric (adjustable) Slide Gib Locking Screw
—	10 108754	—	10 108754	Feed Eccentric (adjustable) Slide Gib
—	11 620(830)	—	11 620(830)	Feed Eccentric (adjustable) Slide Gib Adjusting Screw
—	12 107763	—	12 107763	Feed Eccentric (adjustable) Push Button Circlip
—	13 350754(869)	—	13 350754(869)	Feed Eccentric (adjustable) Push Button Set Screw
—	14 108764	—	14 108764	Feed Eccentric (adjustable) Push Button Bush
—	15 446(830)	—	15 446(830)	Feed Eccentric (adjustable) Push Button Bush Set Screw
—	16 108763	—	16 108763	Feed Eccentric (adjustable) Push Button Return Spring
—	17 108762	—	17 108762	Feed Eccentric (adjustable) Push Button with plastic moulding

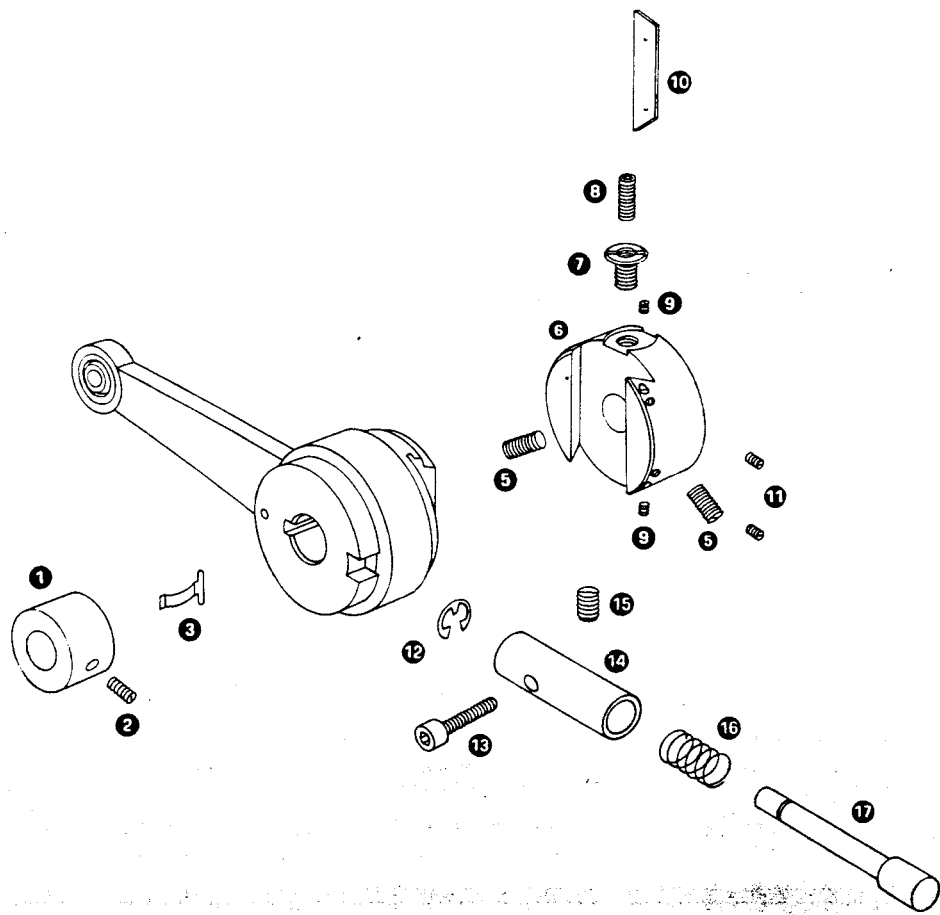

Parts List for 993B43, 993BX43, 993B50 and 993BX50 Machines fitted with Chain Cutters

Items common to all varieties

Ref. No.	Part No.	Description
—	114224(869)	Chain Cutter Knife Holder and Feed Bar Guide Pin Securing Screw
1	108621	Chain Cutter Knife Holder and Feed Bar Guide Oil Deflector
2	108623	Chain Cutter Knife Holder and Feed Bar Guide Cover Suction Tube Oil Seal
3	207(809)	Chain Cutter Knife Holder and Feed Bar Guide Cover Securing Screw (2)
4	108499	Chain Cutter Knife Holder and Feed Bar Guide Cover
5	50027(823)	Chain Cutter Knife Holder and Feed Bar Guide Cover (top) Securing Screw
7	108648	Chain Cutter Knife Holder and Feed Bar Guide Cover (top) Gasket
8	108503	Chain Cutter Knife Holder and Feed Bar Guide Cover Seal (inner)
9	115331	Chain Cutter Knife (movable) Shaft
10	1329(805)	Chain Cutter Knife (stationary) Extension Screw (2)
11	115333	Chain Cutter Knife (stationary) Extension
13	115227	Chain Cutter Knife (movable) Shaft Drive Collar with three 141087(869)
14	141087(869)	Chain Cutter Knife (movable) Shaft Drive Collar Set Screw (2)
15	108394	Chain Cutter Knife (movable) Spring
16	115228	Chain Cutter Knife (movable) with 115240
17	1329(805)	Chain Cutter Knife (stationary) Screw
18	115332	Chain Cutter Knife (stationary)
19	108441	Chain Cutter Knives Oil Wick
20	109927(869)	Chain Cutter Knife (movable) Driving Fork Set Screw (2)
21	108389	Chain Cutter Knife (movable) Driving Fork with two 109927(869)
22	108495	Chain Cutter Knife (movable) Driving Slide Block Stud Wick
23	108391	Chain Cutter Knife (movable) Driving Slide Block Stud with 108495
24	108390	Chain Cutter Knife (movable) Driving Slide Block Mated Components may be supplied only as 108597.
25	108597	Chain Cutter Knife (movable) Driving Fork 108389 with 108390 and 108391
26	109927(869)	Chain Cutter Knife (movable) Driving Slide Block Stud Set Screw
27	1445(830)	Chain Cutter Knife Holder and Feed Bar Guide Oil Deflector Securing Screw (front)
28	665(809)	Chain Cutter Knife Holder and Feed Bar Guide Oil Deflector Securing Screw (rear)
29	108864	Chain Cutter Knife Holder and Feed Bar Guide Oil Deflector Securing Screw (rear) Washer
30	115240	Chain Cutter Knife (movable) Drive Pin
31	665(809)	Chain Cutter Knife Holder and Feed Bar Guide Cover Securing Screw (lower) (2)
32	141087	Chain Cutter Knife (movable) Drive Pin Securing Screw
33	108585	Chain Cutter Suction Pipe Clip (supplied only when specified on order and at an extra charge)
34	108406	Chain Cutter Suction Pipe (supplied only when specified on order and at an extra charge)
—	115035	Cloth Plate
—	115036	Cloth Plate complete, Nos. 1700(809), 51408(832), 115035, 165287 and two 237(809)
—	115066	Machine Frame Oil Splash Guard (top)
—	115037	Machine Frame Oil Splash Cover with 108608
—	115038	Machine Frame Oil Splash Guard
—	108627	Machine Frame Oil Splash Support

Items which differ according to variety

	993B43	993BX43	993B50	993BX50	
6	115033	115033	115050	115050	Chain Cutter Knife Holder and Feed Bar Guide Cover (top)
—	115045	115041	115047	115043	Thread Looper Plate Cover with 109927(869)
—	115046	115042	115048	115044	Thread Looper Plate Cover assembly
12	115032	115032	115064	115064	Chain Cutter Knife Holder and Feed Bar Guide

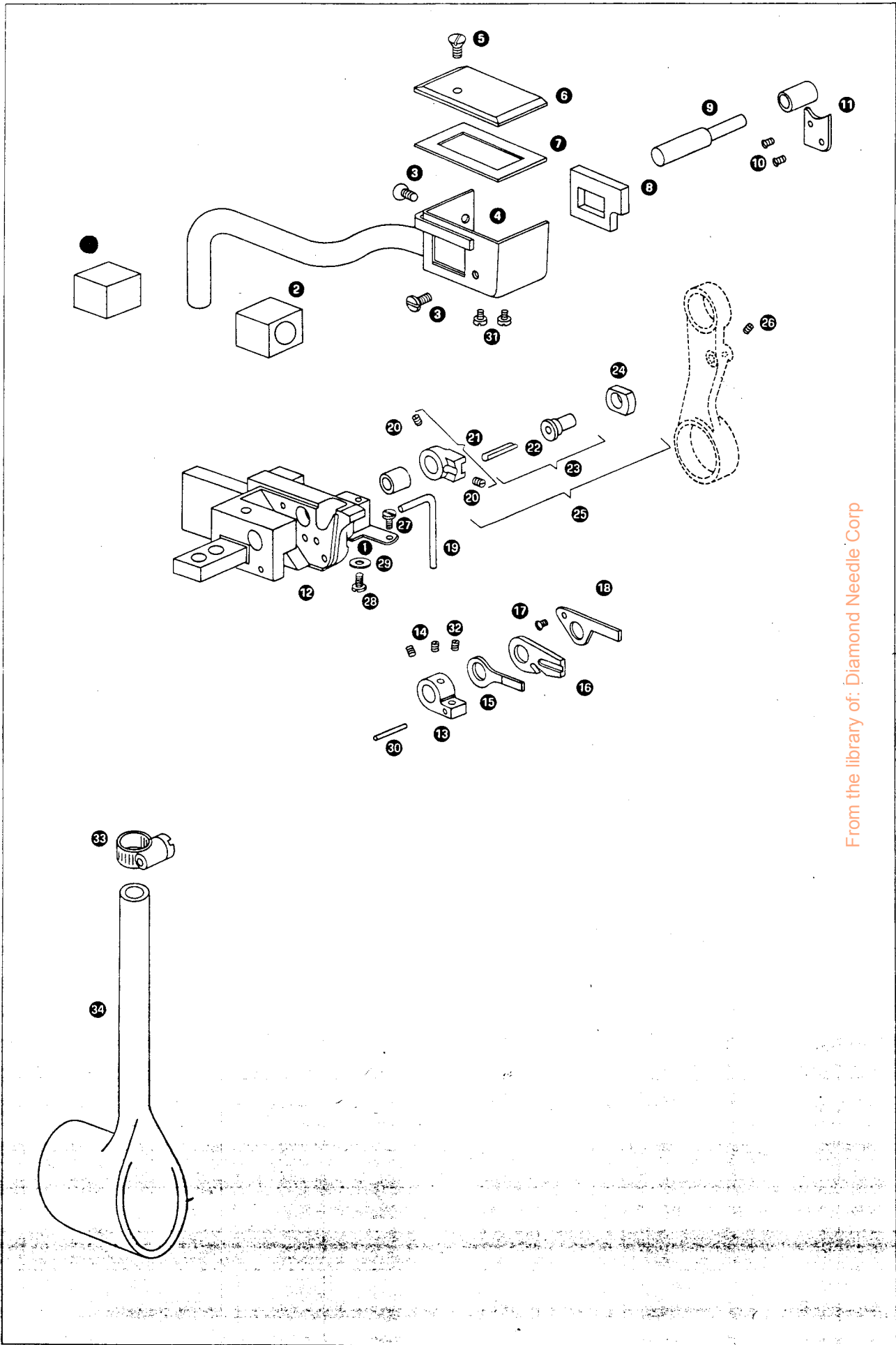

From the library of: Diamond Needle Corp

Numerical List of Parts—993 Machines

Part No.	Page	Part No.	Page	Part No.	Page	Part No.	Page
157	56	8905	78	106460	72	107161	60
168	58	9525	52, 56, 76	106461	72	107169	70
171	54	9842	76	106462	72	107176	56
172	80	10875	74	106463	72	107177	62
176	74	17022	58, 68	106464	60	107178	66
185	58	20822	54	106466	60	107185	56
187	68	23250	78	106471	60	107188	60
190	68	39541	72	106472	60	107192	60
198	60	42436	64, 72	106473	54	107204	70
207	86	49109	74	106477	54, 54	107501	78
208	56	50025	66	106478	54	107502	78, 78
225	54	50027	86	106492	54	107505	78
227	72	50073	64, 72	106494	54	107512	78
236	56	50150	56, 84, 84	106496	54	107513	78
237	72	50169	64	106497	54	107514	76
399	66	50225	64	106498	54	107546	78
435	84, 84	50311	80	107029	70	107575	60
440	60	50429	58	107033	62	107620	66
446	84, 84	50611	60	107034	62	107625	66
447	60, 60, 60	51082-002	78	107037	54	107626	78
448	62, 62	51089	78	107039	72	107627	74
453	80, 80	51145	58	107040	66, 82, 82	107763	84, 84
460	64	51302	58, 60, 60	107042	72	107827	58
462	64	51362	64	107044	72	107829	56
468	84, 84	51369	54, 62	107045	62, 82, 82	107832	60
620	84, 84	51408	58, 72	107046	62, 82, 82	107839	66
624	60, 64	51581	78, 78	107059	72	107854	52
665	86, 86, 86, 86	51723	78, 78, 78	107060	72	107857	52
691	66	51768	66	107064	62	107859	52
704	52, 58, 58, 72	51797	76	107065	62	107898	52
792	56	51846	64	107066	62	107870	52
853	54	59456	52, 54	107067	62	107891	70
858	80	67425	78, 78, 78, 78	107068	70	107898	70, 70
1036	62	81231	76	107069	70	107936	74
1083	54, 54, 62	81350-011	74	107070	70	107944	82, 82
	56, 64, 68, 72	81443	74	107071	70	107953	58
1094	56, 64, 68,	81444	74, 80	107074	70	107954	72
	72, 76	82253	74	107075	70	107955	62
1100	56	82281	64	107076	70	107965	52
1122	80	82309	66	107077	70	107970	56
1209	52, 54, 68, 72,	82312	66	107078	70	108989	76
	72	82313	66	107079	70	108012	52
1231	56	82330	64	107080	64	108013	58
1238	66, 72	82538	80	107081	64	108026	62
1239	68, 70	87027	54	107082	64	108031	68
1259	60	87029	60	107083	64, 82, 82	108040	70
1324	54	87262	60	107084	66	108057	74
1329	86, 86	87279	56, 84, 84	107085	66, 66, 82, 82	108058	74
1423	66, 68	101896	68	107086	66	108063	70
1443	68, 72	101921	80	107087	66	108065	74
1445	58, 86	101948	82, 82	107088	66	108071	60
1454	56, 56, 70	101970	54	107090	72, 72	108075	52
1607	68	106132	60	107095	68	108087	58
1628	58, 58, 60, 60	106144	64	107096	68	108089	56
1637	72	106401	70	107097	68	108104	70
1689	66	106430	72, 82, 82	107098	72	108112	82, 82
1700	54, 64, 72, 76	106452	60	107102	66	108113	70
1735	58	106454	60	107105	76	108115	74
2102	66	106456	64	107107	76	108123	74
3146	60	106457	64	107156	76	108132	52
5599	78	106458	72	107157	76	108133	52
5601	78	106459	72	107158	70	108134	52

From the Gray of Diamond Needle Corp.

Numerical List of Parts—993 Machines

Part No.	Page	Part No.	Page	Part No.	Page	Part No.	Page
108135	52	108623	86	114133	54	141292	52, 52, 52, 54
108141	56	108627	86	114134	52, 52		56, 56, 56, 56
108145	52	108630	72	114136	54		58, 60, 62
108146	74	108632	66	114142	72	141420	58
108147	74	108633	64, 82, 82	114159	64	141444	60
108148	74	108635	82	114172	56	149224	70
108160	58	108648	86	114200	84, 84	150203	80
108205-008	64, 82, 82	108656	70, 70	114201	84, 84	151023	80
108213	60	108659	82, 82	114224	54, 58, 60	151024	80
108214	72	108660	82, 82		72, 86	151025	80
108217	76	108661	82, 82	115032	86, 86	151026	80
108219	76	108663	82	115033	86, 86	151027	80
108220	76	108753	84, 84	115035	86	151028	80
108221	78	108754	84, 84	115036	86	151029	80
108222	78	108755	84, 84	115037	86	151030	80
108223	78	108757	84, 84	115038	86	151162	80
108224	74	108762	84, 84	115041	86	152080	78
108225	52	108763	84, 84	115042	86	152153	78
108227	56	108764	84, 84	115043	86	152168	78, 78, 78
108228	72	108765	82, 82	115044	86	152171	78, 78, 78
108229	56, 82, 82	108766	82, 82	115045	86	161294	74
108232	58	108777	74	115046	86	164004	56
108336	52	108779	82	115047	86	164011	56
108371	54	108780	82	115048	86	164019	56, 82, 82
108373	52, 72	108781	82	115050	86, 86	164042	78
108389	86	108782	82	115064	86, 86	164043	60
108390	86	108783	82, 82	115066	86	164046	54
108391	86	108812	68	115140	82	164053	54, 54, 66
108394	86	108818	66, 82, 82	115141	82	164068	54
108406	86	108864	86	115142	82	164091	68
108436	72	108890	58	115143	68	164098	62
108441	86	108891	58	115179	56	164100	62
108445	62	108917	54	115182-982	74	164139	64
108446	62	108919	54	115183-982	74	164141	64
108452	74	108921	66	115227	86	164143	64
108456-982	74	108925	54	115228	86	164144	64
108461-982	74	108941	82, 82	115240	86	164146	64
108462-982	74	109795	54	115254	58	164147	64
108463-982	74	109876	66	115255	58	164149	64
108464-982	74	109898	72	115256	58	164157	66
108483	58	109927	54, 68, 86, 86	115263	58	164163	68
108495	86	109935	66	115328-982	74	164164	74
108499	86	113176	60, 72	115331	86	164165	68
108502	56	113179	70	115332	86	164189	76
108503	86	113180	66, 66, 66	115333	86	164196	74
108585	86		82, 82	115418	78, 78, 78	164202	54
108592	74	113191	66	115420	78, 78, 78	164351	64
108597	86	113194	52	115421	78	164416	64
108598	62	114032	60	125399	72	164449	68
108600	72, 82, 82	114038	70	131695	52, 58	164462	66
108601	72, 82, 82	114072	60	132584	54	164525	60
108604	66	114073	72	139026	62	164550	60, 74
108606	72	114077	62	140159	54	164555	68
108607	72	114080	70	140208	66	164617	82, 82
108608	72	114081	70	140393	54, 78	164627	82, 82
108609	56	114082	64, 72	140416	62	164660	54
108612	54	114083	64	140509	72	164661	54
108615	68	114091	54	140510	64	164727	74
108616	68, 82	114092	54	140596	54	164728	60, 74
108617	68, 82	114116	76	140930	54, 54	164744	60
108619	72	114117	66	141087	86, 86	164745	60
108621	86	114130	60	141223-002	78	164861	82, 82
				141004	60		

From the library of: Diamond Needle Corp

Numerical List of Parts—993 Machines

Part No.	Page	Part No.	Page	Part No.	Page	Part No.	Page
164863	82, 82	165305	56	165373	52	350680	54, 64
164864	82, 82	165306	56	165384	70	350687	52
164865	82, 82	165307	58	165395	70	350719	66
165058	66, 82, 82	165308	58	165399	58	350744	70
165062	60	165309	58	165406	66	350754	84, 84
165063	60	165310	58	165487	60	701679	74
165064	60	165311	56, 58	165519	70	820193-002	74
165108	82, 82	165315	58	175032	68, 76	820193-003	74
165135	56	165323	58	201018	80	820193-005	74
165148	80	165326	56	201528	80	820193-007	74
165157	70	165330	56	225259	80	820193-009	74
165259	56, 58	165347	58	228661	72, 82, 82	820193-010	74
165287	72	165348	58	228692	80	931084	66
165290	72	165349	58	350606	56, 58	Cat. 1431	66, 74, 82, 82
165301	56	165350	58	350647	62, 76	Cat. 1435	82, 82
165303	56	165351	58	350656	58		